

UtiliGuard[®] Series

Operator's Manual



Issue 2.0

053-2831

ORIGINAL INSTRUCTION

Overview

Chapter Contents

Serial Number Location	2
System Components	3
Accessory Ports	4
Intended Use	8
Regulatory Notices	9
• United States	9
• Canada	10
• EU Declaration of Conformity	10
About This Manual	11
• Bulleted Lists	11
• Numbered Lists	11

California Proposition 65 Warnings



Cancer, birth defects, and other reproductive harm. www.P65warnings.ca.gov

Serial Number Location

Record serial numbers and date of purchase in spaces provided. Unit serial number is located as shown.

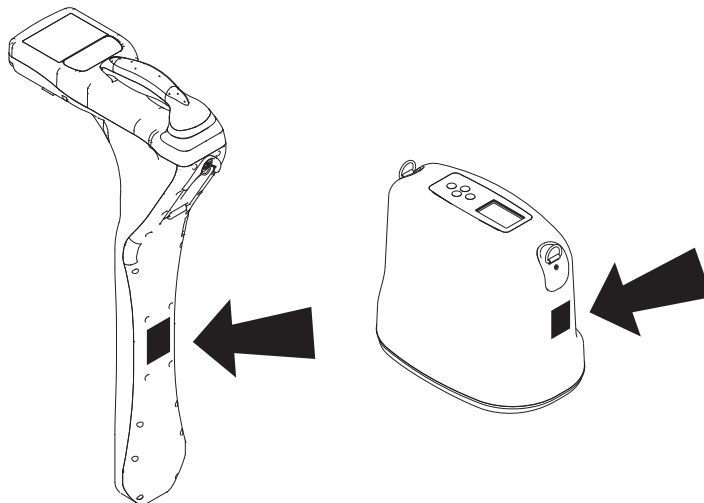

e18om029h.eps

Item	
date of purchase:	
receiver serial number:	
transmitter serial number:	

System Components

Receiver (RX)

Model Description	Standard Features	Important
UtiliGuard B	Receiver with 5 frequencies, upgradeable	
UtiliGuard	Receiver: up to 100 frequencies, configuration software, upgradeable	
UtiliGuard w/ Bluetooth	Receiver: up to 100 frequencies, configuration software, Bluetooth transmitter, upgradeable	
UtiliGuard 2	Receiver: Integrated GPS, up to 100 frequencies, configuration software, Bluetooth transmitter, upgradeable	
UtiliGuard+	Receiver: up to 100 frequencies, configuration software, radio transmitter, RX/TX communication, Ambient Interference Measurement (AIM®)	If using with software version 22 or higher, UtiliGuard+ transmitters will need to be updated to software version 12 or higher
UtiliGuard 2+	Receiver: Integrated GPS, up to 100 frequencies, configuration software, radio transmitter, RX/TX communication, Ambient Interference Measurement (AIM®)	

Transmitter (TX)

Model Description	Standard Features	Important
UtiliGuard T5B	Transmitter with 5-watt power output, 4 frequencies, upgradeable	
UtiliGuard T5	Transmitter: 5-Watt output, up to 100 frequencies, configuration software, upgradeable	
UtiliGuard T5+	Transmitter: 5-Watt output, up to 100 frequencies, configuration software, RX/TX communication	If using with software version 12 or higher, UtiliGuard+ receivers will need to be updated to software version 22 or higher
UtiliGuard T12	Transmitter: 12-Watt output, up to 100 frequencies, configuration software, upgradeable	
UtiliGuard T12+	Transmitter: 12-Watt output, up to 100 frequencies, configuration software, RX/TX communication	If using with software version 12 or higher, UtiliGuard+ receivers will need to be updated to software version 22 or higher

Accessory Ports

Receiver (RX)

Accessory Port (1)

This port is intended to be used with only Subsite® Electronics approved accessories such as the fault finding probe. Only use accessories that meet Subsite Electronics specifications.

Accessory Port (1) Pinout

Pin	Description
1	3.0Vdc (50mA max)
2	Digital input/output OR UART Rx (115.2 kbps) (logic 3.0Vdc)
3	Digital input/output OR UART RX (115.2 kbps) (logic 3.0Vdc)
4	Analog input (0-3.0Vdc) (Accessory ID)
5	Digital input/output OR Analog input (logic 3.0Vdc)
6	Common

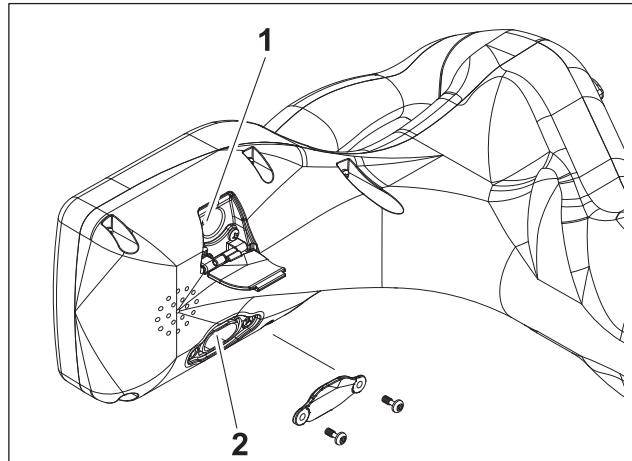

e18om050h.eps

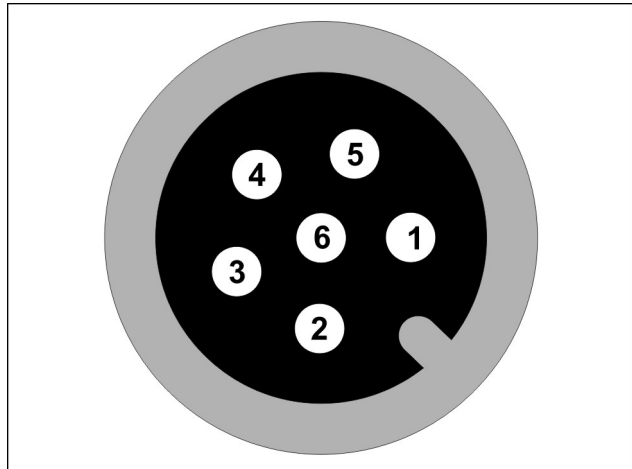

e18om082h.eps

Mini-USB Port (2):

This port is intended to be used for connecting to a PC to update software and change the user configuration of the receiver using the PC software.

Mini-USB Port (2) Pinout

Pin	Description
1	VBUS
2	USB Data -
3	USB Data +
4	N/C
5	Device ground

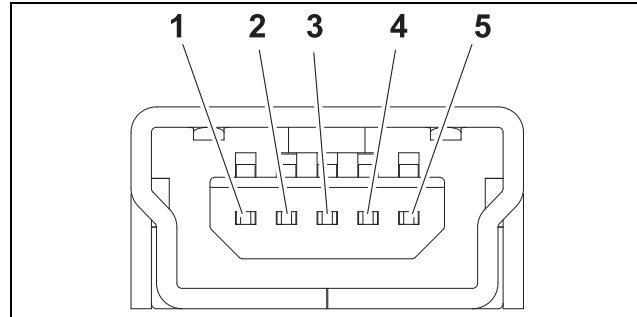

This USB port does not provide 5Vdc on pin 1, but the receiver is powered by the 5Vdc from the PC USB while connected to the PC. Only connections to safety certified devices are allowed (e.g. IEC61010-1, UL/ IEC 62368-1).

IMPORTANT: Always replace sealed cover over USB connector after use.

Transmitter (TX)

The transmitter has three auxiliary ports:

1. Mini-USB port
2. External power connector port
3. Active location device port

IMPORTANT: All leads, test probes, and external circuits that connect to the transmitter must provide reinforced electrical insulation to protect the user and must meet the requirements of the safety standard IEC 61010-1:2010.

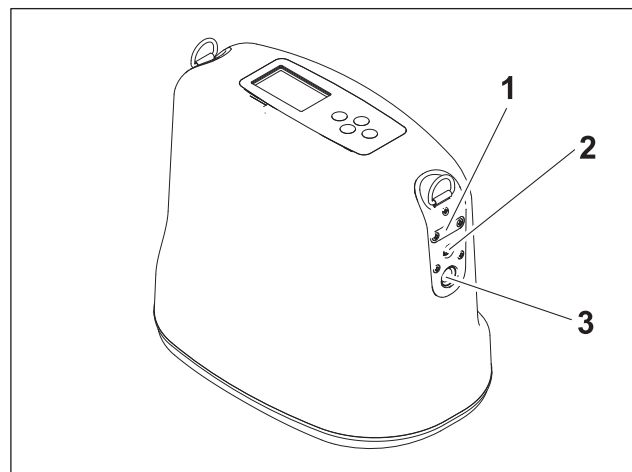

e18om051h.eps

Mini-USB Port (1):

This port is intended to be used for connecting to a PC to update software and change the user configuration of the transmitter using the PC software.

Pinout

Pin	Description
1	VBUS
2	USB Data -
3	USB Data +
4	N/C
5	Device ground

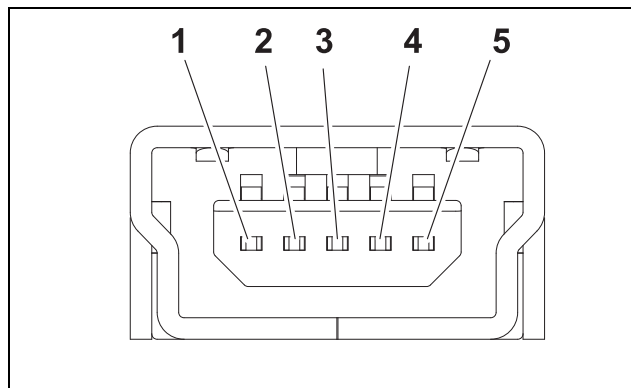

This USB port does not provide 5Vdc on pin 1. When connected to the PC, the transmitter's display and control logic only are powered from the 5Vdc from the PC USB port.

IMPORTANT: Always replace sealed cover over USB connector after use.

External Power Connector (2):

This connector is intended to be used for an optional 12Vdc supply to power the transmitter. Only use a power supply with a voltage output rating of 10-15Vdc and with current rating of 2.5A maximum.

Connect

only with Subsite® approved external power cable and fusing (p/n 222-3808).

Pinout

Pin	Description
1	10-15Vdc input
2	10-15Vdc input
3	Device ground
4	Device ground

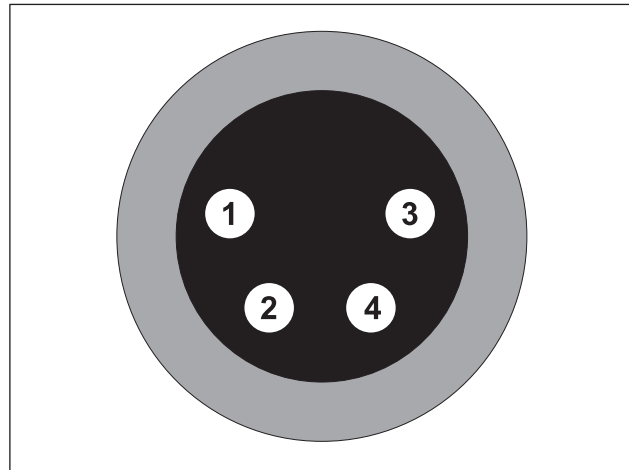

e18om054h.eps

Active Location Device Port (3)

This port is intended to be used with only Subsite® Electronics approved accessories such as the direct connect cable, Live Power Adapter, or induction clamp. Only use accessories that meet Subsite Electronics specifications.

Pinout

Pin	Description
1	Output 1 (AC 256Hz to 200kHz, 75Vrms max) (500mA max)*
2	Output return
3	Direct connect ID (3.3V or device ground) identifies the direct connect cable when attached
4	Inductive clamp ID (3.3V or device ground) identifies the induction clamp when attached
5	Device ground
6	Output 2 (AC 256Hz to 200kHz, 75Vrms max) (500mA Max)*

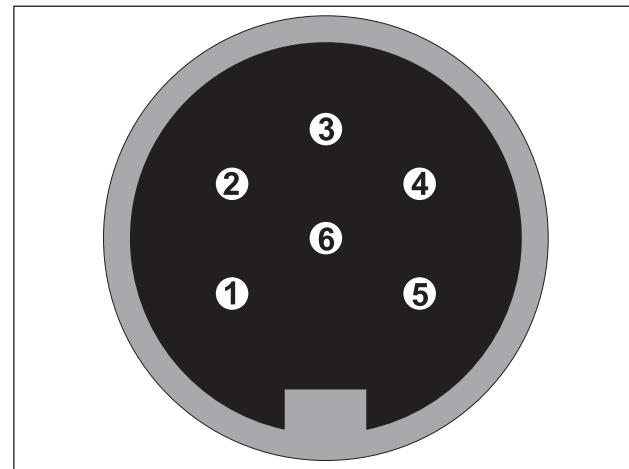

e18om055h.eps

*Both outputs cannot be used at the same time

Intended Use

The UtiliGuard Series receivers are designed to locate buried pipes and cables. Over 70 frequencies and four modes of operation are available to suit your specific locating needs. The UtiliGuard B receiver is offered without all options described and will be configured when ordered.

The T5 and T12 transmitters place signals on target cables to be detected by UtiliGuard Series receivers. These units can be configured to send over 70 frequencies as well as custom frequencies. The transmitters place a signal on the cable through either direct connection, induction clamping, or broadcast modes. The UtiliGuard T5B transmitter is offered without all options described and will be configured when ordered.

The fault probe accessory is designed to locate fault signals generated by transmitters in de-energized cables that are disconnected on both ends. It allows users to find faults on direct-buried power, telephone, cable, and sheathed tracer wire.

The EML accessory is designed to locate electronic markers on pipes and cables. It allows users to find any standard electronic marker, used to mark specific locations for future locating.

The Live Power Adapter is intended to protect the transmitter from damage due to connection to live electrical power.

The receiver clamp accessory is used to identify a target line in a vault or utility box with multiple lines.

The stethoscope accessory is used to identify lines in cabinets with multiple lines.

The Bluetooth[®] Accessory is used to extend Bluetooth functionality of UtiliGuard locating receivers to improve connectivity with certain GPS devices.

Only connections to safety certified devices are allowed (e.g. IEC 61010, UL/IEC 62368-1) with USB port.

The system is designed for operation in temperatures typically experienced in earth moving and construction work environments. Use in any other way is considered contrary to the intended use. The UtiliGuard Series system should be operated only by persons familiar with its particular characteristics and acquainted with the relevant safety procedures, otherwise the protection provided by the equipment in this system may be impaired. The system should be serviced only by Subsite[®]Electronics repair centers.

Regulatory Notices

United States

This device complies with Part 15 of the FCC Rules. Operation is subject to the following two conditions: (1) this device may not cause harmful interference, and (2) this device must accept any interference received, including interference that may cause undesired operation.

Changes or modifications not expressly approved by **The Charles Machine Works, Inc.** could void the user's authority to operate the equipment.

This equipment has been tested and found to comply with the limits for a Class B digital device, pursuant to Part 15 of the FCC Rules. These limits are designed to provide reasonable protection against harmful interference in a residential installation. This equipment generates, uses, and can radiate radio frequency energy and, if not installed and used in accordance with the instructions, may cause harmful interference to radio communications. However, there is no guarantee that interference will not occur in a particular installation. If this equipment does cause harmful interference to radio or television reception, which can be determined by turning the equipment off and on, the user is encouraged to try to correct the interference by one or more of the following measures:

- Reorient or relocate the receiving antenna.
- Increase the separation between the equipment and receiver.
- Connect the equipment into an outlet on a circuit different from that which the receiver is connected.

Contact your equipment dealer with questions.

The following products may contain FCC ID: QQQWT41

- UtiliGuard w/Bluetooth®
- UtiliGuard+
- UtiliGuard 2
- UtiliGuard 2+
- UtiliGuard T5+
- UtiliGuard T12+

The following may contain FCC ID: T7VEBMU

- Bluetooth Accessory, V1
- Bluetooth Accessory, V2

Canada

This device contains license-exempt transmitter(s)/receiver(s) that comply with Innovation, Science and Economic Development Canada's license-exempt RSS(s). Operation is subject to the following two conditions (1) This device may not cause interference, (2) This device must accept any interference, including interference that may cause undesired operation of the device.

Le présent appareil est conforme aux CNR Innovation, Sciences et Développement économique Canada applicables aux appareils radio exempts de licence. L'exploitation est autorisée aux deux conditions suivantes: (1) l'appareil ne doit pas produire de brouillage, et (2) l'appareil doit accepter tout brouillage radioélectrique subi, même si le brouillage est susceptible d'en compromettre le fonctionnement.

CAN ICES-003(B)/NMB-3(B)

Equipment is for use by trained operators only and not for general household use. Usage duration shall be as short as possible to prevent possible radio interference to authorized services, especially the 100kHz eLoran frequency.

Contact your equipment dealer with questions.

The following products may contain IC: 5123A-BGTWT41

- UtiliGuard w/Bluetooth[®]
- UtiliGuard+
- UtiliGuard 2
- UtiliGuard 2+
- UtiliGuard T5+
- UtiliGuard T12+

The following may contain IC: 216QEBMU

- Bluetooth Accessory, V1
- Bluetooth Accessory, V2

EU Declaration of Conformity

Hereby, Charles Machine Works declares that the radio equipment type *UtiliGuard buried utility locating equipment* is in compliance with Directive 2014/53/EU. The full text of the EU declaration of conformity is available by visiting <https://subsite.com/about-us/contact-us> or by emailing a request to service@subsite.com.

About This Manual

This manual contains information for the proper use of this equipment. Cross references such as “See page 50” will direct you to detailed procedures.

Bulleted Lists

Bulleted lists provide helpful or important information or contain procedures that do not have to be performed in a specific order.

Numbered Lists

Numbered lists contain illustration callouts or list steps that must be performed in order.

Foreword

This manual is an important part of your equipment. It provides safety information and operation instructions to help you use and maintain your Subsite® Electronics equipment.

Read this manual before using your equipment. Keep it with the equipment at all times for future reference. If you sell your equipment, be sure to give this manual to the new owner.

If you need a replacement copy, contact your Ditch Witch® dealer. If you need assistance in locating a dealer, visit our website at www.subsite.com, email info@subsite.com or write to the following address:

Subsite Electronics
Attn: Product Support
1950 W. Fir
Perry, OK 73077
USA

The descriptions and specifications in this manual are subject to change without notice. Subsite Electronics reserves the right to improve equipment. Some product improvements may have taken place after this manual was published. For the latest information on Subsite Electronics equipment, see your Ditch Witch dealer.

Thank you for buying and using Subsite Electronics equipment.



A CHARLES MACHINE WORKS COMPANY

**UtiliGuard[®] Series
Operator's Manual**









**Issue number 2.0/OM-10/19
Part number 053-2831
Copyright 2015, 2018, 2019
by The Charles Machine Works, Inc.**



Subsite, Ditch Witch, UtiliGuard, and AIM are registered trademarks of The Charles Machine Works, Inc. Underground Awareness is a trademark of The Charles Machine Works, Inc.

This product and its use may be covered by one or more patents at <http://patents.charlesmachine.works>.

Contents

	Overview machine serial number, information about the type of work this machine is designed to perform, basic machine components, and how to use this manual	1
	Foreword part number, revision level, and publication date of this manual, and factory contact information	13
	Safety machine safety alerts and emergency procedures	17
	Control Icons control menus and display icon descriptions	21
	Locate procedures for locating active, passive and beacon signals	43
	Service service intervals and instructions for this machine	85
	Specifications machine specifications including weights, measurements and power rating	91
	Support the warranty policy for this machine, and procedures for obtaining warranty consideration and training	99

Safety

Chapter Contents

Guidelines	18
Safety Alert Classifications	19
Safety Alerts	20

Guidelines

Follow these guidelines before operating any jobsite equipment:

- Complete proper training and read operator's manual before using equipment.
- Contact your local One-Call (811 in USA) or the One-Call referral number (888-258-0808 in USA and Canada) to have underground utilities located before working. Also contact any utilities that do not participate in the One-Call service. Classify jobsite based on its hazards and use correct tools and machinery, safety equipment, and work methods for jobsite.
- Mark jobsite clearly and keep spectators away.
- Wear personal protective equipment.
- Review jobsite hazards, safety and emergency procedures, and individual responsibilities with all personnel before work begins.
- Replace missing or damaged safety signs.
- Use equipment carefully. Stop operation and investigate anything that does not look or feel right.
- Contact your equipment dealer if you have any question about operation, maintenance, or equipment use.

Safety Alert Classifications

These classifications and the icons defined on the following pages work together to alert you to situations which could be harmful to you, jobsite bystanders or your equipment. When you see these words and icons in the book or on the unit, carefully read and follow all instructions. **YOUR SAFETY IS AT STAKE.**

Watch for the three safety alert levels: **DANGER**, **WARNING** and **CAUTION**. Learn what each level means.

 **DANGER** indicates an imminently hazardous situation which, if not avoided, will result in death or serious injury.

 **WARNING** indicates a potentially hazardous situation which, if not avoided, could result in death or serious injury.

 **CAUTION** indicates a potentially hazardous situation which, if not avoided, may result in minor or moderate injury.

Watch for two other words: **NOTICE** and **IMPORTANT**.

NOTICE can keep you from doing something that might damage the unit or someone's property. It can also alert you against unsafe practices.

IMPORTANT can help you do a better job or make your job easier in some way.

Safety Alerts

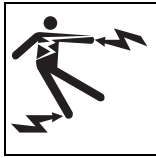

⚠ DANGER Electric shock. Contacting electric lines will cause death or serious injury. Know location of lines and stay away.

To help avoid injury:

- Do not use live power adapter unless you are properly qualified to work on live power conductors.
- Check that equipment is in good condition and that test leads are clean and have no cracked insulation.
- Have qualified utility personnel disconnect both ends of cable before working.
- Do not operate transmitter near explosive devices or blasting operations.



⚠ WARNING Jobsite hazards could cause death or serious injury. Use correct equipment and work methods. Use and maintain proper safety equipment.

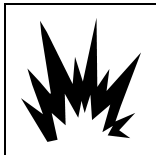

⚠ WARNING Explosion possible. Serious injury or equipment damage could occur. Follow directions carefully.

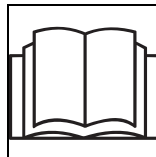

⚠ WARNING Read operator's manual. Know how to use all controls. Your safety is at stake.



⚠ WARNING Moving traffic - hazardous situation. Death or serious injury could result. Avoid moving vehicles, wear high visibility clothing, post appropriate warning signs.



⚠ WARNING HIGH VOLTAGE. This device produces electric current that could cause death or serious injury. Do not touch the clips on the HV output unless wearing electrically insulating gloves. Follow proper procedures.



⚠ WARNING Battery cells inside may vent or rupture. Do not crush, do not heat or incinerate, do not short circuit, do not dismantle, do not immerse in any liquid. Observe charging instructions.

Control Icons

Chapter Contents

Receiver	22
• Keypad	22
• Display, UtiliGuard	23
• Display, UtiliGuard 2	24
• Menus, UtiliGuard	25
• Menus, UtiliGuard 2	27
Transmitter	29
• Keypad	29
• Display	30
• Menus	31
Fault Finder Accessory	32
• Receiver Display	32
• Transmitter Display	34
EML Accessory	35
• Receiver Keypad	35
• Receiver Display	36
Receiver Clamp Accessory	37
Stethoscope Accessory	38
GPS Capability	39
• Receiver Display, UtiliGuard	40
• Receiver Display, UtiliGuard 2	41





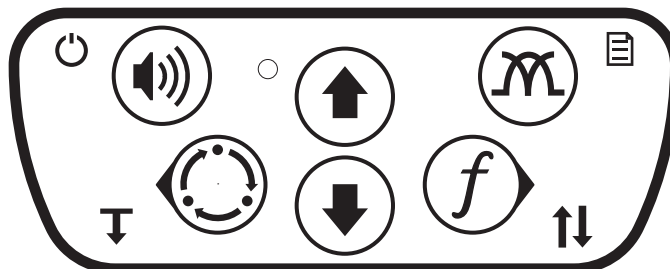







Receiver

Receiver Keypad



e18om007h.eps

Keypad buttons perform several functions depending on operating mode. To activate most functions, press and release the button. For other functions, press and hold the button until the function activates.

Receiver Keypad Icons		
 Power ON/OFF (press and hold)	 Up	 Antenna Configuration
 Volume Exit Menu		 Menu (press and hold)
 Location Mode  Back  Depth (press and hold)	 Down	 Frequency  Select / Next  Set or reset Direction Enable (press and hold)

Receiver Display, UtiliGuard

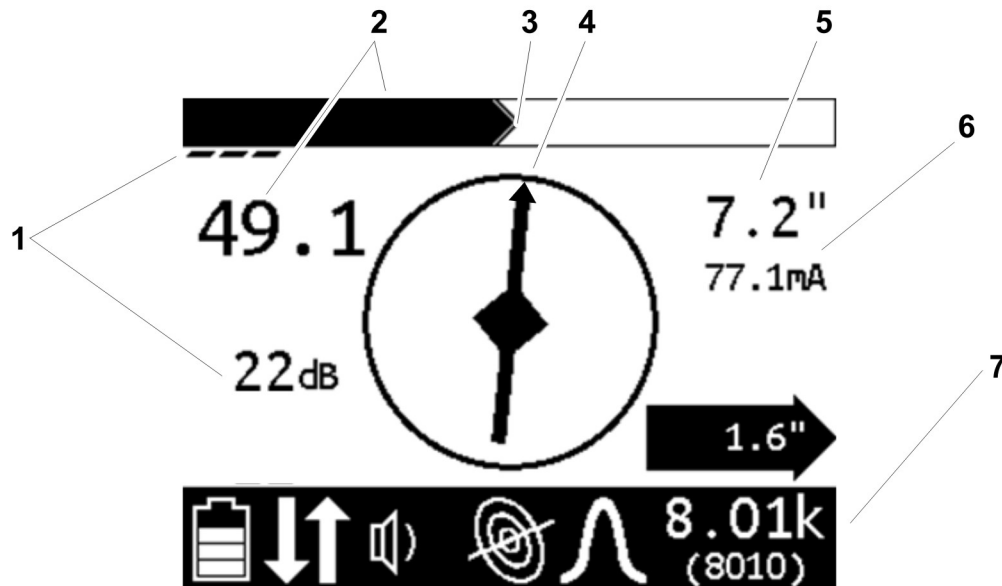

- | | |
|--------------------|--------------------------------|
| 1. Gain | 5. Estimated depth |
| 2. Signal strength | 6. Current meter |
| 3. Peak signal | 7. Unit status bar (see below) |
| 4. Compass | |

Status Bar Icons

Battery level	Line mode	Twin peak antenna
Battery exhausted (receiver will shut off)	Auto Gain mode	Null antenna
Direction enable feature active	Beacon mode	Single peak antenna
Volume level	Radio mode	Total field antenna
No communication from transmitter	Power mode	
Frequency not available from transmitter	Fault mode *	
	EML mode *	Selected frequency setting
	Receiver Clamp mode *	
	Stethoscope mode *	
		* Shown when accessory is connected

Receiver Display, UtiliGuard 2

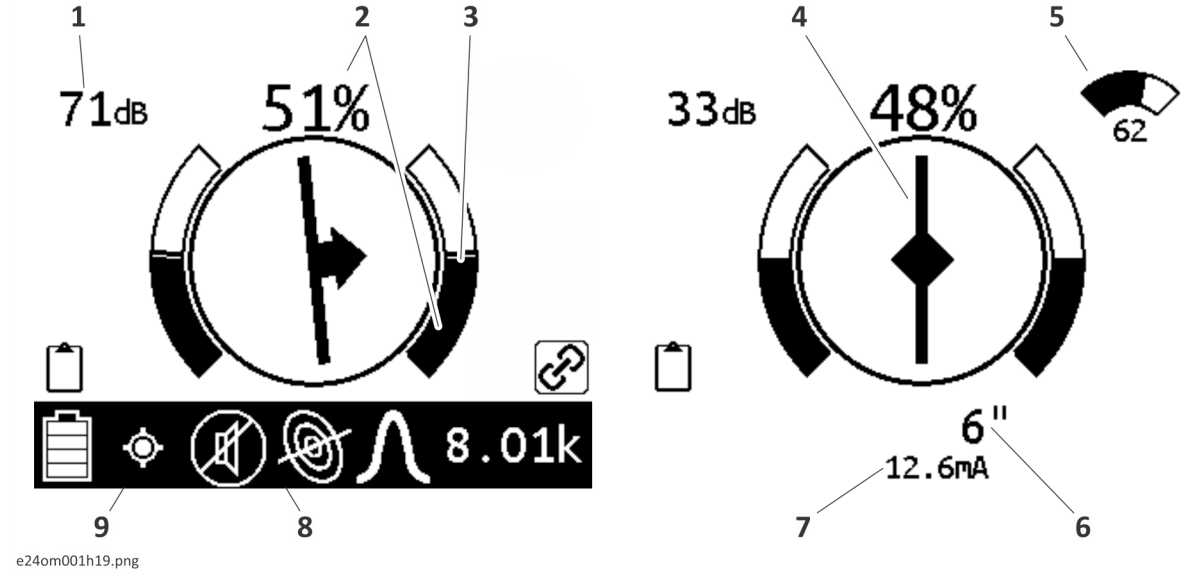





















- 1. Gain
- 2. Signal strength
- 3. Peak signal
- 4. Compass
- 5. Range estimator
- 6. Estimated depth
- 7. Current meter
- 8. Unit status bar (see below)
- 9. GPS data receive status





Status Bar Icons

Battery level	Line mode	Twin peak antenna
Battery exhausted (receiver will shut off)	Auto Gain mode	Null antenna
GPS data receive status	Beacon mode	Single peak antenna
Volume level	Radio mode	Total field antenna
No communication from transmitter	Power mode	Selected frequency setting
Frequency not available from transmitter	Fault mode *	*Shown when accessory is connected
Linked to transmitter (advanced units)	EML mode *	
	Receiver Clamp mode*	
	Stethoscope mode*	

Receiver Menus, UtiliGuard

















Menus allow the operator to set user interface preferences. Use the up, down, select/next, and back buttons on the keypad to navigate the menu.



Receiver Menu Icons		
 Configuration	 Frequencies	Select frequencies to activate. Icons show which mode is suited for each frequency:  Power  Beacon  Line
	 Modes	Select modes to activate.
	 Antennas	Select antennas to activate.
 Settings	 Language	Select user interface language
	 Units	Select measurement units for distance and depth
	 Backlight	Select backlight setting
	 Shutdown Timer	Set amount of time before unit shuts off
	 Communications	Select communication preference
 Options	 Audio	 Audio Mode - Select audio mode setting
		 Audio Style - Select audio style setting
		 Center Beep - Select center beep options
	 Gain	Select gain options
	 L/R Arrows	Turn left and right arrows on or off
	 Autodepth	Select automatic or manual depth



Receiver Menu Icons		
 System Information	 System Info	Displays the receiver model configuration, model number, serial number, software version, hour count, configuration date, and calibration date.
 AIM [®]	Ambient Interference Measurement; measures and displays interference (noise) at all frequencies in the selected mode. See page 49.	
 TX Control	Displays transmitter information.	









Receiver Menus, UtiliGuard 2

Menus allow the operator to set user interface preferences. Use the up, down, select/next, and back buttons on the keypad to navigate the menu..

Receiver Menu Icons		
 Configuration	 Frequencies	Select frequencies to activate. Icons show which mode is suited for each frequency:  Power  Beacon  Line
	 Modes	Select modes to activate.
	 Antennas	Select antennas to activate.
	 Settings	Select modes to activate.
	 Options	Select antennas to activate.
 Utility type	 Utility type	Select type of utility to locate.
 Metrics	 Metrics	Displays RX metrics.
 System Information	 System Info	Displays the receiver model configuration, model number, serial number, software version, hour count, configuration date, and calibration date.
 AIM®	Ambient Interference Measurement; measures and displays interference (noise) at all frequencies in the selected mode. See page 49.	
 TX Control	Displays transmitter information.	

Settings Menu Icons		
 Language	Select user interface language	
 Units	Select measurement units for distance and depth	
 Backlight	Select backlight setting	

Settings Menu Icons		
 Shutdown Timer	Set amount of time before unit shuts off	
 Communications	Select communication preferences.	In Bluetooth [®] settings: Select high security for iOS devices. Select normal security for non-iOS and external GPS devices.

Options Menu Icons		
 Audio	 Audio Mode - Select audio mode setting	
	 Audio Style - Select audio style setting	
	 Center Beep - Select center beep options	
 Gain	Select gain options	
 L/R Arrows	Turn left and right arrows on or off	
 Autodepth	Select automatic or manual depth	
 Offset Depth	Select offset depth setting	
 User Interface	Select user interface	

Transmitter



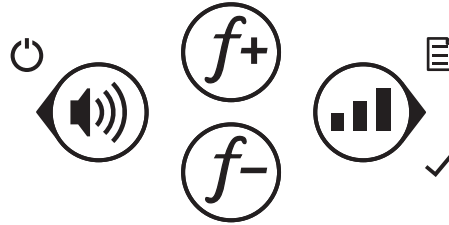



Transmitter Keypad



e18om009h.eps

Keypad buttons perform several functions depending on operating mode. To activate most functions, press and release the button. For other functions, press and hold the button until the function activates.

Transmitter Keypad Icons

	Power ON/OFF (press and hold)	f_+ Frequency / Up		Power output
	Volume	f_- Frequency / Down		Select / Next
	Back			Menu (Press and hold)



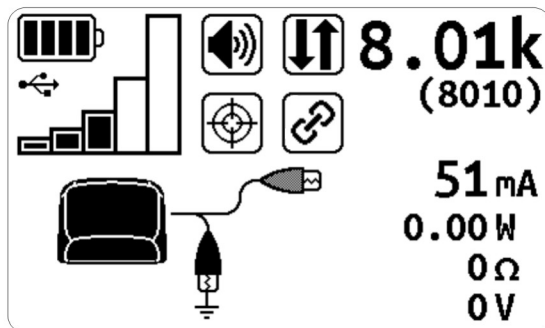











Transmitter Display



e18om010h.jpg



















The transmitter display shows the status of selected options as well as the active frequency and meter reading.

Transmitter Display Icons

 Battery level  External power connected	 Volume on  Volume off	 Linked to receiver
 USB connected	 Direction enable active	 Inductive clamp connected
 Output power level  High power output enabled	 Output has reached regulation  Output interrupted	 Induction active  Direct-connect leads connected

Transmitter Menus

Menus allow the operator to set user interface preferences. Use the up, down, select/next, and back keypad buttons to navigate the menu.

Transmitter Menu Icons		
 Settings	 Backlight	Select backlight setting
	 Output	Select output setting:  Direction enable  Dual output  High power output
	 Meter	Select simple or advanced meter
	 Communications	Select communication preference
 Options	 Language	Select user interface language
	 Defaults	Restores unit to factory default settings.
	 Shutdown timer	Set amount of time before unit shuts off
	 Fault mode	Enable or disable fault mode
 Frequencies	Select frequencies to activate.	Icons show which connection can be used for each frequency:  Induction  Direct connect  Induction clamp, standard  Induction clamp, broadband
 System Information	Displays the unit model configuration, model number, serial number, software version, hour count, configuration date, and calibration date.	

Fault Finder Accessory



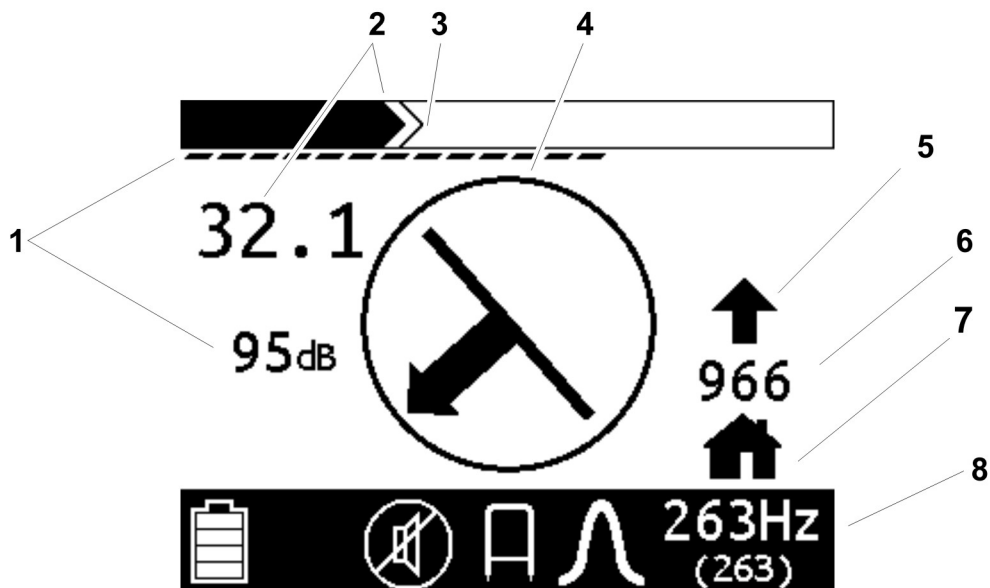

The receiver and transmitter require setup when using the fault finder accessory. Key functions and information displayed will be specific to the fault finder.

Receiver Display, UtiliGuard



- | | |
|--------------------|--------------------------------|
| 1. Gain | 5. Fault direction indicator |
| 2. Signal strength | 6. Current meter |
| 3. Peak signal | 7. Homing indicator |
| 4. Compass | 8. Unit status bar (see below) |

Status Bar Icons

 Receiver battery level	 Fault Mode indicator	Selected frequency setting
 Volume level	 Antenna indicator	



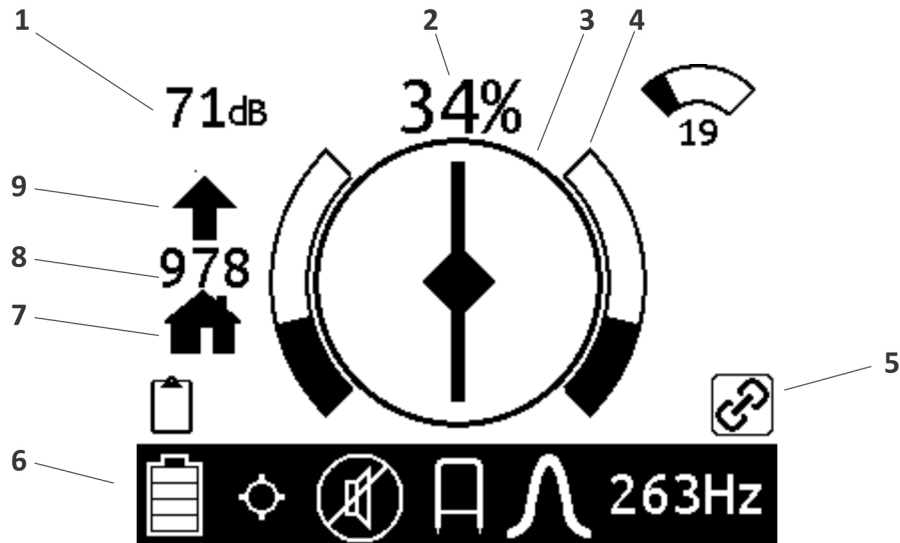

Receiver Display, UtiliGuard 2



e24om012h19.png

- | | |
|--------------------|--------------------------------|
| 1. Gain | 5. Transmitter link indicator |
| 2. Signal strength | 6. Unit status bar (see below) |
| 3. Compass | 7. Homing indicator |
| 4. Peak signal | 8. Current meter |
| | 9. Fault direction indicator |

Status Bar Icons

 Receiver battery level	 Fault Mode indicator	Selected frequency setting
 Volume level	 Antenna indicator	



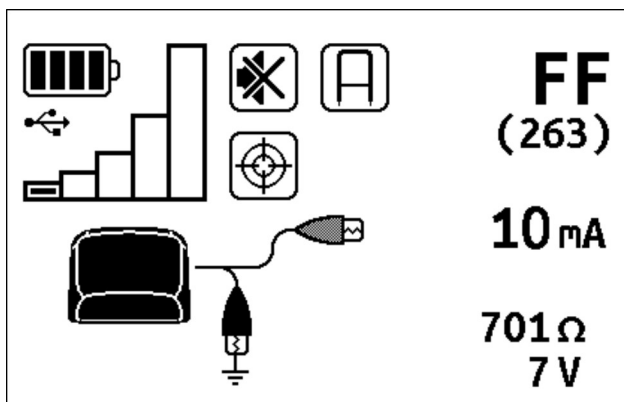









Transmitter Display



e18om066h.jpg

The transmitter display shows the status of selected options as well as the active frequency and meter reading.

Transmitter Display Icons

 Battery level  External power connected	 Volume on  Volume off	 Linked to receiver
 USB connected	 Fault finder mode indicator	 Direct-connect leads connected
 Output power level  High power output enabled	 Output active  Output interrupted	

EML Accessory

Receiver key functions and information displayed will be specific to the EML accessory.

Receiver Keypad

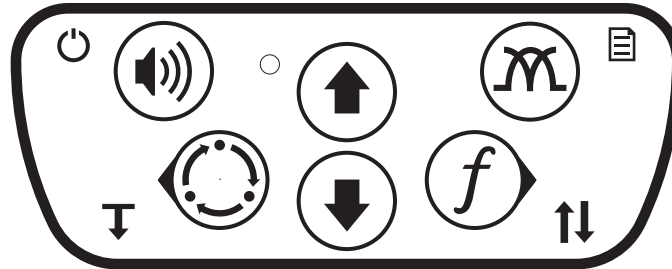

e18om007h.eps







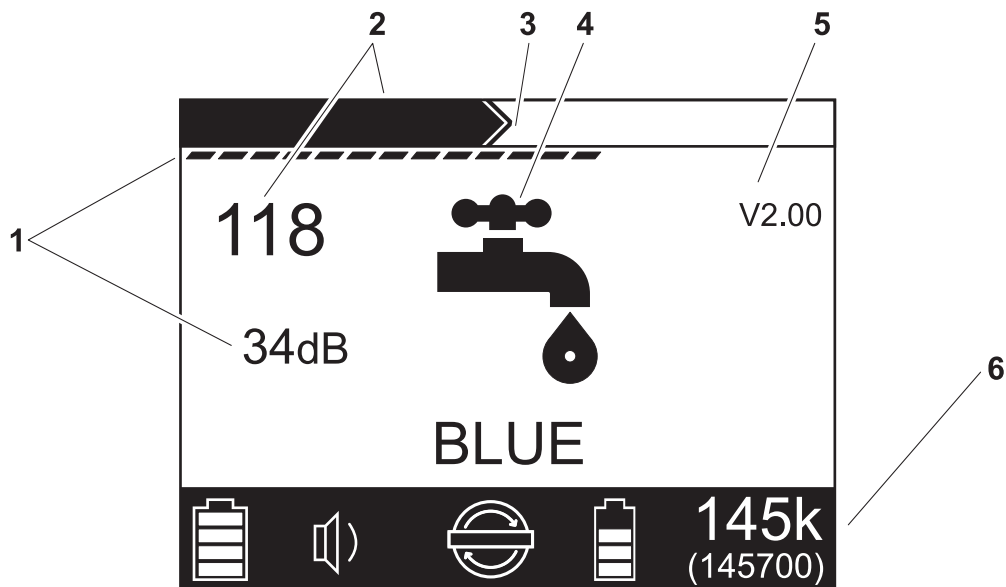





To activate most functions, press and release the button. For other functions, press and hold the button until the function activates.

Receiver Keypad Icons		
Power ON/OFF (press and hold)	Up	not used not used
Volume	Down	Frequency not used not used
Mode selector not used not used		

Receiver Display



- | | |
|--------------------|--------------------------------------|
| 1. Gain | 4. Marker ball indicator (see below) |
| 2. Signal strength | 5. EML accessory software version |
| 3. Peak signal | 6. Unit status bar (see below) |

Status Bar Icons	Marker Ball Indicators
 Receiver battery level	 Water (blue, 145k)  Non-potable water (purple, 66.3k)
 Volume level	 Power (red, 169k, non-EU only)  Power (red/blue, 134k, EU only)
 EML normal mode indicator	 Waste water (green, 121k)
 EML search mode indicator	 Communications (black/orange, 77.0k)
 EML accessory battery level	 Phone (orange, 101k)
selected frequency	 Gas (yellow, 83.0k)

Receiver Clamp Accessory



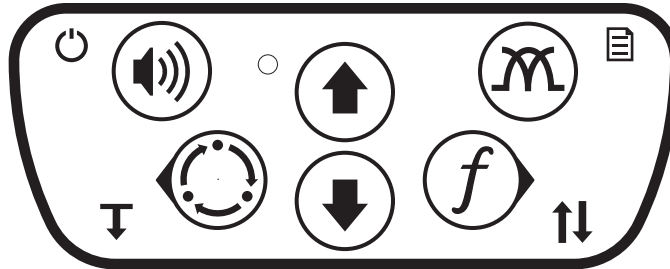

The receiver clamp accessory is used to identify a target line in a vault or utility box with multiple lines.

Receiver Controls Used with Clamp



e18om007h.eps

Receiver key functions and information displayed will be specific to the receiver clamp accessory.

Receiver Keypad Icons		
 Power ON/OFF (press and hold)	 Up	
 Location Mode	 Down	 Frequency

Stethoscope Accessory



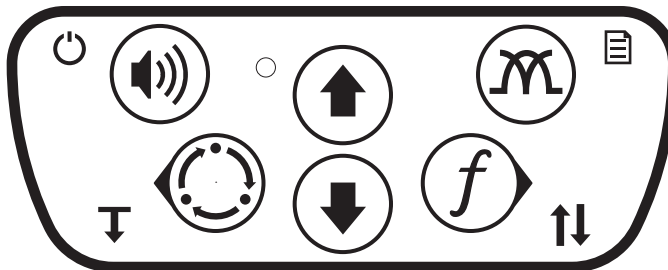

The stethoscope accessory is used to identify lines in cabinets with multiple lines. It has an adjustable neck to make it easier to identify target lines in tight spaces.

Receiver Controls Used with Stethoscope



e18om007h.eps

Receiver key functions and information displayed will be specific to the stethoscope accessory.

Receiver Keypad Icons		
 Power ON/OFF (press and hold)	 Up	
 Location Mode	 Down	 Frequency

GPS Capability



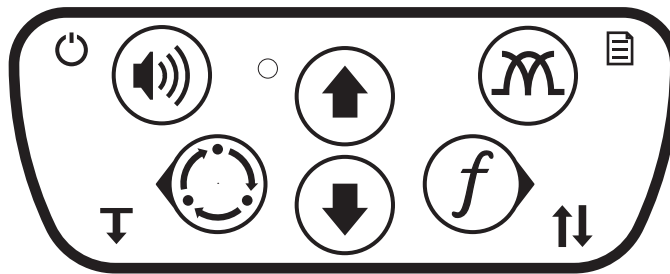

The GPS capability is used to log locate data from the UtiliGuard receiver to the GPS unit or log data in the receiver. This feature is only available on the UtiliGuard+ and UtiliGuard w/ Bluetooth® receivers.

Receiver Controls Used with GPS



e18om007h.eps

Receiver key functions and information displayed will be specific to the GPS accessory.





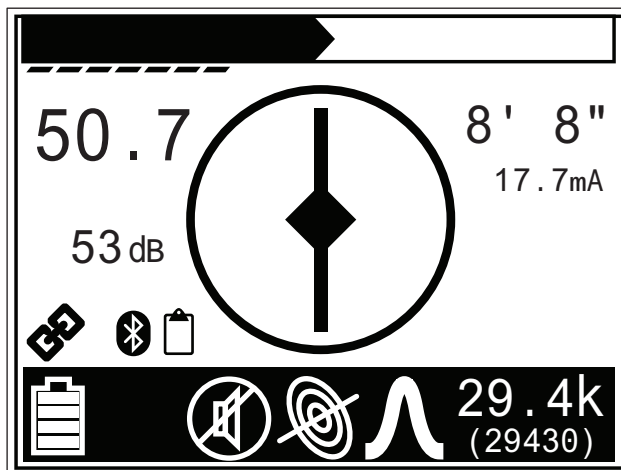

Receiver Keypad Icons		
 Power ON/OFF (press and hold)	 Up	
 Location Mode	 Down	 Frequency

Receiver Display, UtiliGuard





e18om001w.eps

GPS Indicators

 A Bluetooth® connection is active	 Last data point failed to send data to the GPS device
 Flashes once to indicate a data point was logged  Flashes repeatedly to indicate attempt to call external logging GPS device	 Center dot flashes to indicate GPS data being received, but no GPS lock  Lights solid to indicate GPS data being received and GPS lock established

GPS Indicators when using Bluetooth Accessory





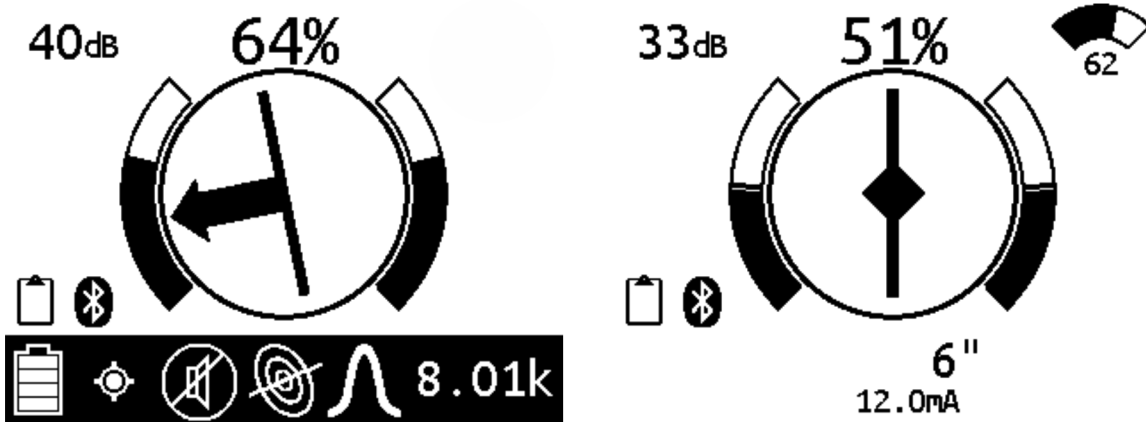

 A Bluetooth accessory connected Solid	 An external logging device is connected
 A Bluetooth connection is being made Blinking	

Receiver Display, UtiliGuard 2



e24om002h19.png

GPS Indicators

 A Bluetooth® connection is active	 Last data point failed to send data to the GPS device
 Flashes once to indicate a data point was logged  Flashes repeatedly to indicate attempt to call external logging GPS device	 Center dot flashes to indicate GPS data being received, but no GPS lock  Lights solid to indicate GPS data being received and GPS lock established

Locate

Chapter Contents

- Prepare 45**
 - Select Mode 45
 - Select Antenna Configuration 46
 - Link Receiver to Transmitter (Advanced Units). 47
 - Select Locating Frequency 48
 - Adjust Receiver Gain 49

- Locate Active Signals 50**
 - Setup. 50
 - Technique 54
 - Advanced Features 55

- Locate Passive Signals 59**
 - Setup. 59
 - Technique 59

- Locate Beacon Signals. 61**
 - Setup. 61
 - Technique 61

- Common Signal Problems 64**

- Locate Faults. 65**
 - Background 65
 - Technique 67











- Locate Markers 71**
 - Setup71
 - Technique72
- Locate Using Receiver Clamp 73**
- Locate Using Stethoscope 74**
- Locate Using GPS 75**
 - Connect75
 - Log Point80
 - Download81
- Use Configuration Management System 82**
 - Configuring Modes and Functions82
 - Locking/Unlocking Configurations83

Prepare

Select Mode





UtiliGuard Series receivers detect active and passive signals. Select the mode best suited for jobsite and user preference. Depending on the receiver model, all modes might not be available.

Signal Mode/Type	Description	Notes
Active Signals:	Signal placed on a target line with a transmitter	
 Line mode	 Direct Connection	(preferred method) requires a connection directly to the target line
	 Clamp Induction	requires placing an optional induction clamp around the target line
	 Broadcast induction	sends current into lines near the transmitter
 Auto Gain mode	Same as line mode	Fully automatic gain control with the left/right audio
 Beacon mode	Signal transmitted from a beacon inside a pipe or conduit	
Passive Signals:	Signal that a utility line picks up from the environment	
 Power mode	Allows receiver to trace live 50 Hz or 60 Hz power cables	IMPORTANT: Current must be flowing through the cable.
 Radio mode	Allows receiver to trace cables that pick up and radiate very low frequency (VLF) radio waves	



Select Antenna Configuration

Select the antenna configuration best suited for the locating jobsite.

Antenna	Description	Advantage / Disadvantage
 Single Peak	Uses one horizontal antenna to detect signal. Response is highest at strongest signal.	more range / less precise
 Twin Peak	Uses two horizontal antenna to detect signal. Response is highest at strongest signal.	noise canceling / most precise / less range
 Null	Uses a vertical antenna to detect signal. Search width is narrower than single peak. Response is lowest when receiver is over the line.	sharp response / easily distorted in congested areas
 Total Field	Uses a combined signal measured in all three axes to locate signal.	easy to use when sweeping and eliminates ghost signals / less precise in congested areas

Link Receiver to Transmitter (Advanced Units)

UtiliGuard+ and UtiliGuard 2+ receivers can be linked to UtiliGuard+ transmitters through a wireless connection. This allows the receiver operator to change transmitter settings through the receiver.

To link the receiver to a transmitter via Radio:

1. Turn both receiver and transmitter on and unlinked.
2. UtiliGuard 1: Navigate to **Settings>Communications** and select **Link TX**.
UtiliGuard 2: Navigate to **Configuration>Settings>Communications** and select **Link TX**.
3. Select "Link RX" from the **Settings>Communications** menu in the transmitter.
4. Select a device to link. Link is complete when the link icon is displayed.

IMPORTANT: Once linked, devices automatically connect when turned on. To unlink devices, navigate to **Settings>Communications** and select **Unlink**.

5. When linked, changing the receiver frequency will also change the transmitter frequency and temporarily show the transmitter information (as shown).

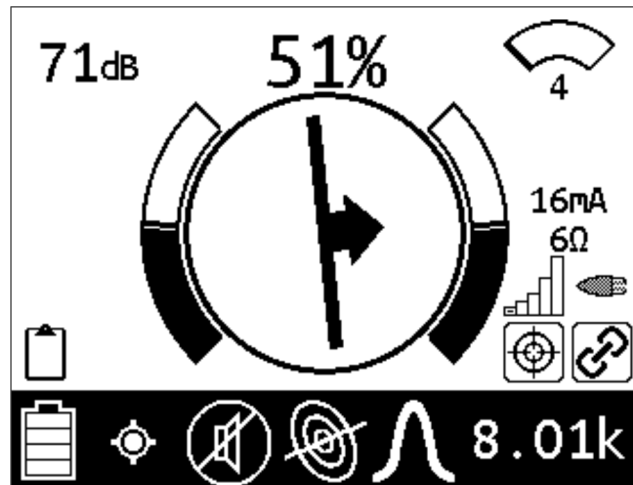

Select Frequency

IMPORTANT: 12 watt power level only available in Direct Connect mode and only for frequencies below 9KHz.

The UtiliGuard system gives the user the ability to choose from up to 100 different frequencies. Not all frequencies are available at 5 watt and 12 watt power levels. F1/F2 is a dual output of 8k and 29K. Power output is reduced when using F1/F2. This frequency choice is not available when transmitter is set to high output. Optimal frequencies for your area can be configured for each unit using UtiliGuard software. Use the UtiliGuard+ AIM[®] (Ambient Interference Measurement) application to determine suitable frequencies. Then, use the transmitter and receiver frequency menus to activate only the frequencies most suited for a particular jobsite. Be aware of these points:

- Lower frequencies travel farther than higher frequencies.
- Higher frequencies couple onto lines more easily.
- Higher frequencies also couple onto lines other than the target line more easily.

Enable Frequencies

To enable frequencies on the transmitter as well as the receiver:

1. Navigate to **Configuration>Frequency** menu.
2. Select the frequencies best suited for the jobsite conditions. When the box is checked, the frequency is enabled.

Note: Power, line, and beacon icons indicate which mode a frequency will be available in.

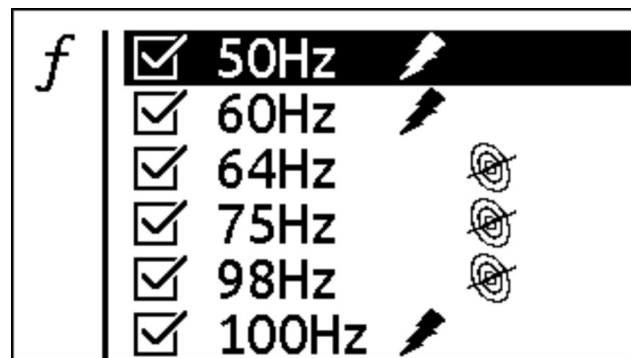

e18om035h.jpg

3. While locating, press the **Frequency** button to select the next enabled frequency.



Measure Ambient Interference (Advanced Units)

The UtiliGuard+ AIM® (Ambient Interference Measurement) application measures interference on the jobsite. For best locating, select a frequency with the least amount of interference. Interference levels are indicated numerically and graphically.

To measure ambient interference:

1. Ensure that transmitter output is turned off.
2. From the receiver menu, select the **AIM** function.

The receiver will scan the surrounding area for interference on all frequencies enabled in the selected mode.

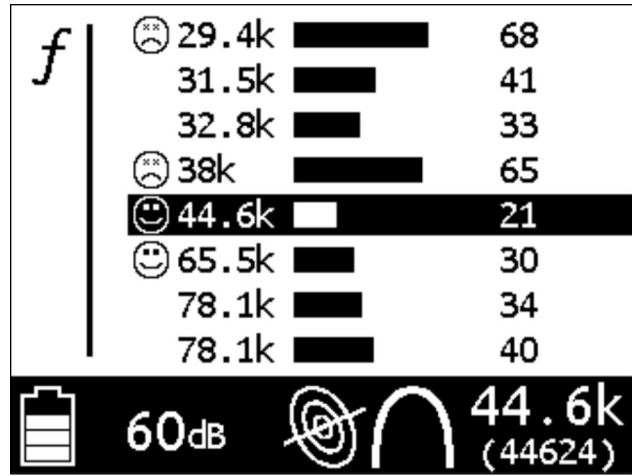

-  frequencies with the least amount of interference
-  frequencies with a large amount of interference



e18om030h.jpg

3. Highlight the desired frequency and press the Next button to exit the menu.

IMPORTANT:

- If a line is connected to an active signal, the ambient interference measurement will be high.
- When a frequency is highlighted, a realtime interference is displayed.
- The  and  are reversed for passive (power) modes.

Adjust Receiver Gain

The receiver gain setting controls the sensitivity to the signal.

Action	Result	Effect
increasing gain	more sensitive to signal	allows location farther away from signal source
decreasing gain	less sensitive to signal	stabilizes signal

Locate Active Signals

Setup

Follow setup procedures for the type of locating you will be doing: direct connection, induction clamp, connecting to live power with live power adapter, or broadcast induction. For all types of active location that require leads, connect leads to transmitter at connector (2). When it is necessary to connect to external power, use connector (1).

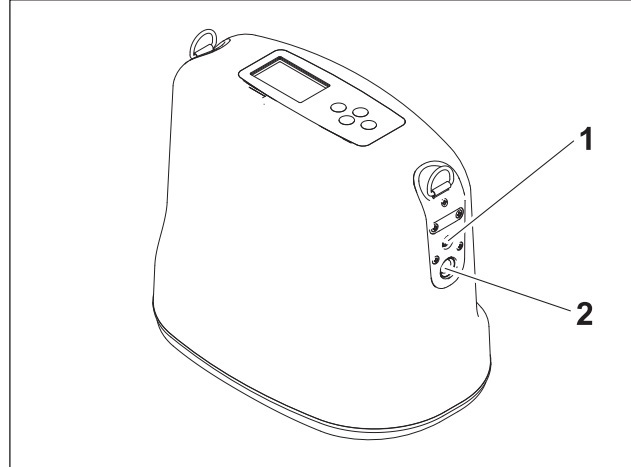

e18om016h.eps

Induction Clamp

WARNING

Jobsite hazards could cause death or serious injury. Use correct equipment and work methods. Use and maintain proper safety equipment.

To help avoid injury:

- Contact qualified utility personnel and follow all standards and requirements for disconnecting and grounding cables. Electric shock or equipment damage can result if transmitter is connected to live cable.
- Ensure transmitter output is on standby or off before opening broadband clamp.

To set up transmitter for use with induction clamp:

1. Plug cable into transmitter.
2. Place clamp around cable.
3. Turn on transmitter.
4. Check battery level.

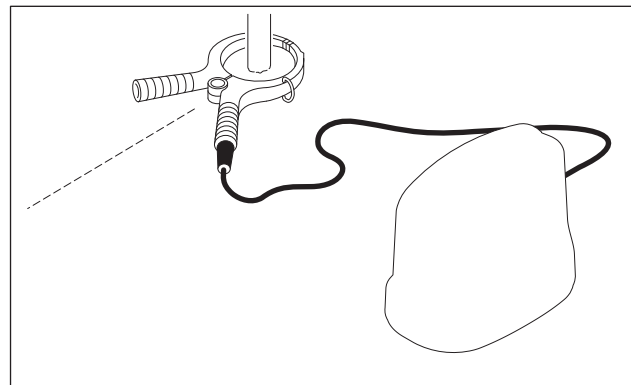

e18om022h.eps

Direct Connection



WARNING Jobsite hazards could cause death or serious injury. Use correct equipment and work methods. Use and maintain proper safety equipment.

To help avoid injury:

- Electric shock or equipment damage can result if transmitter is connected to live cable. Contact qualified utility personnel and follow all standards and requirements for disconnecting and grounding cables.
- A built-in circuit breaker will automatically disable transmitter when leads are connected to a live cable. Display will flash and transmitter will beep. Turn off transmitter and disconnect from cable to reset breaker.



To set up transmitter for direct connection:

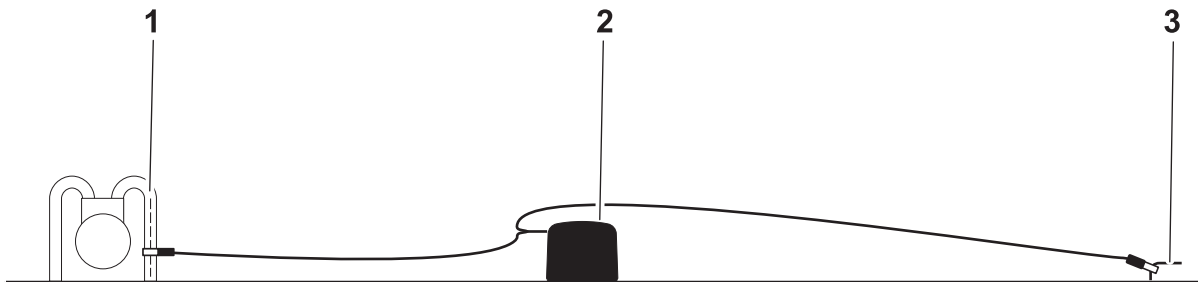

e18om028h.eps

1. Carefully push ground stake (3) into ground.
2. Plug cable into transmitter (2).
3. Connect black lead to ground stake.
4. Connect red lead to cable (1).

Note: If using dual location, connect white lead to the additional cable to be located.

5. Turn on transmitter and check battery level.

IMPORTANT: Turn off transmitter when connecting or moving ground stake.

Connect with Live Power Adapter**⚠ WARNING**

Jobsite hazards could cause death or serious injury. Use correct equipment and work methods. Use and maintain proper safety equipment.

To help avoid injury:

- Read and follow all safety precautions.
- Do not work with this device unless you are properly qualified to work on live power conductors.
- Use proper personal protective equipment for voltage and current of power conductor being connected to as defined by OSHA standards.
- Do not work with this device unless you have completed proper training and have read the operator's manual.
- Do not connect to a conductor with a voltage greater than 480V.
- Connect this device to the transmitter before connecting to the live power conductor. Connect only one clamp at a time to live power conductor.
- Inspect cables for damage. Replace accessory if cables are damaged.

To set up transmitter for use with live power adapter:

1. Verify that transmitter (1) is turned off.
2. Connect live power adapter (2) to the transmitter.
3. Connect live power adapter black lead to the ground stake (4).
4. Connect live power adapter red lead to live power conductor (3).

5. Turn on transmitter.
6. Select frequency greater than 8 kHz (29 kHz is preferred).
7. Adjust power level as needed.
8. Check battery level.

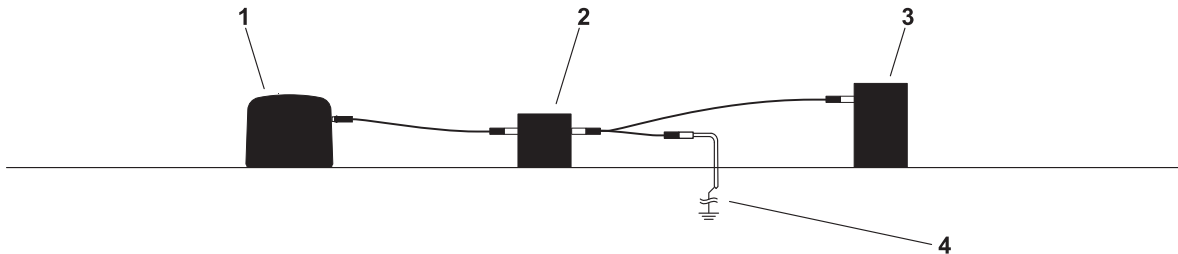

e18om020h.eps



IMPORTANT: When finished locating the cable, turn off transmitter, disconnect live power adapter red lead from live power conductor, disconnect live power adapter black lead from ground stake, and disconnect live power adapter from transmitter.

Induction

To set up transmitter for induction:

1. Remove cable, stake, clamp and any other metal objects from transmitter.
2. Place transmitter parallel to and directly above suspected cable as shown.

IMPORTANT: Transmitter must be parallel to object, as shown, in order to produce the best signal.

3. Turn on transmitter.
4. Check battery level.

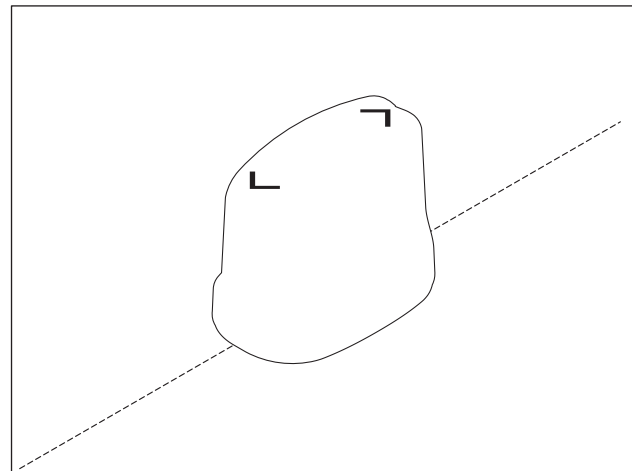

e18om025h.eps

Technique

1. Facing away from the transmitter, walk in an arc approximately 25' (A, 7.5 m) around transmitter, as shown above.

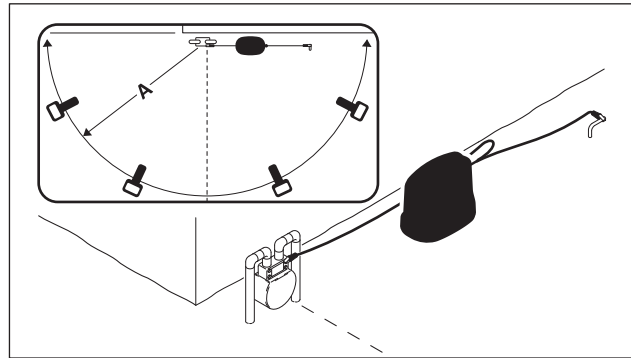

e24om009h19.eps

2. Rotate the receiver and observe the screen:
 - Target is located where signal response (1) is strongest. Signal strength is shown graphically as well as numerically. The signal strength number will flash when the receiver is saturated. Reduce the gain until the number stops flashing.
 - Adjust gain as needed to maintain signal strength. Gain is shown graphically (6) as well as numerically.
 - The compass line (2) shows the direction the cable runs.
 - Move in the direction of the center arrows. When the arrows form a diamond (3), the target is located.
 - AutoDepth reading (4) will appear when target is correctly located. If operating in Manual depth mode, press and hold the **Depth** button.
 - Use current measurement (5) to identify target cable. Current on the target cable should be higher than current on another cable that is picking up signal inductively from target cable.
3. Continue to trace the cable and observe depth estimates every few paces.
4. Retrace the cable and mark with appropriate flags or paint.

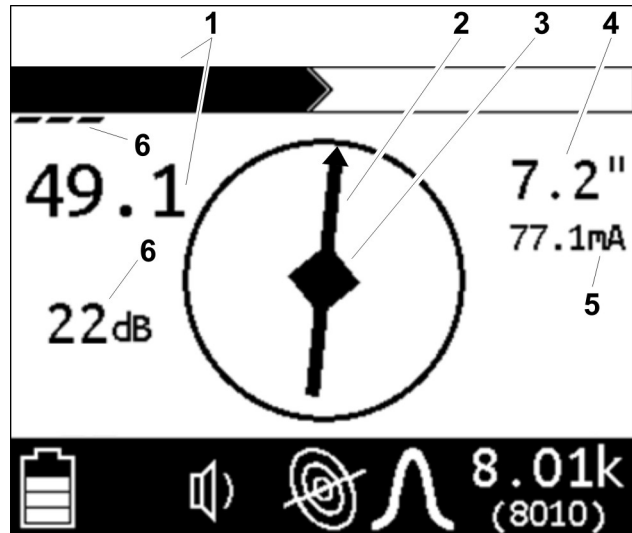

e18om036h.jpg

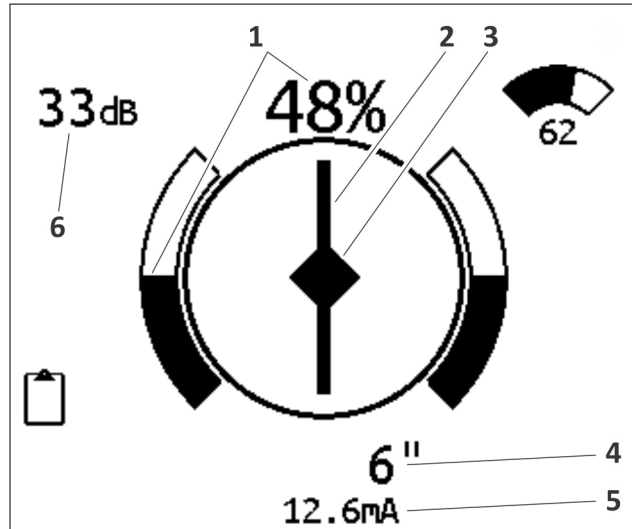

e24om003h19.png

Use Advanced Features

Direction Enable

Direction Enable allows the operator to set a reference for current flow on a target line. It is useful for maintaining line identity on jobsites where multiple utilities are present. Direction Enable is only available:

- on UtiliGuard, UtiliGuard+, UtiliGuard 2, and UtiliGuard 2+ units;
- in line location mode; and
- at frequencies of 10kHz and below.

To use Direction Enable:

1. On the transmitter menu, navigate to **Settings>Output>Direction Enabled** and select "Enable."
2. Ensure the function is available by looking for the Direction Enable icon (1) on the transmitter.
3. Stand approximately 10 ft (3 m) from the transmitter with the receiver positioned so that the compass heading (3) is parallel to the target line. Face away from the transmitter.
4. Press and hold the Frequency button to set the direction of current flow. An arrow (2) will appear on the compass heading.
5. Continue locating.

IMPORTANT:

- Power output is reduced when Direction Enable is in use.
- Direction Enable is not available when transmitter is set to High Output.

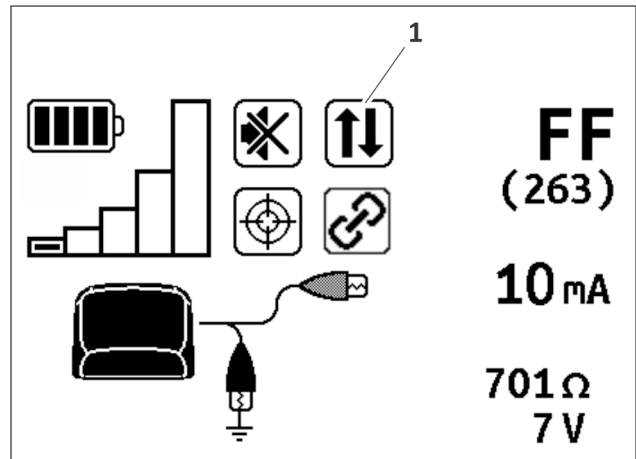

e24om014h19.png

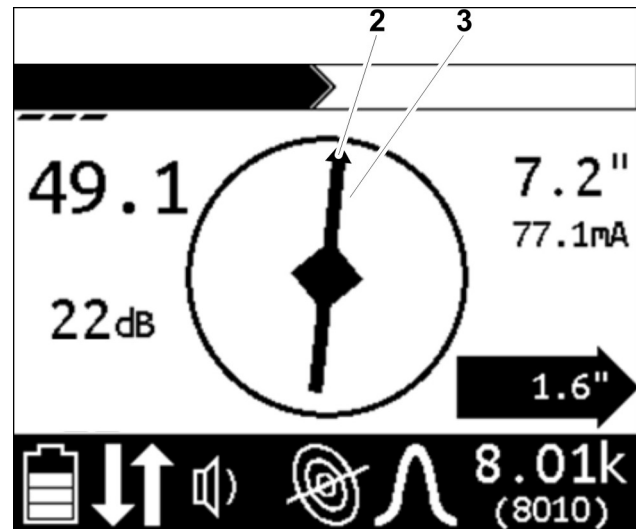

e18om037h.jpg

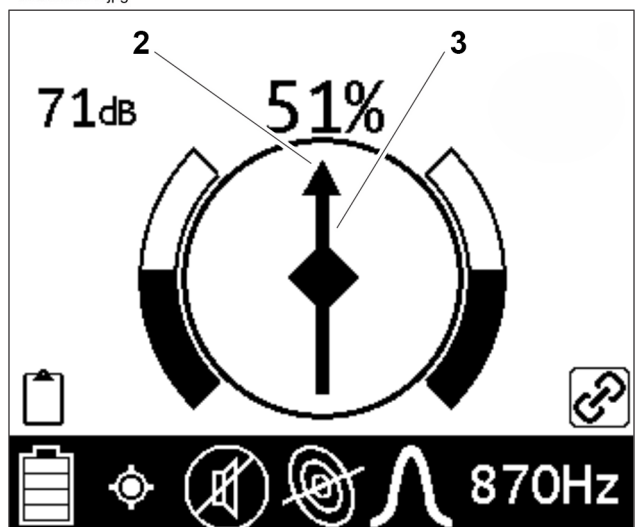

e24om004h19.png

Offset Depth

Offset Depth assists in locating a target line that cannot be accessed from directly above due to obstruction. The function uses available data to estimate horizontal distance (X) and depth (D). Offset depth is only available in UtiliGuard+ and UtiliGuard 2+ units

1. On the receiver menu, navigate to **Options>Offset Depth** and select "Enable".
2. Begin by holding receiver parallel to line.
3. Tilt receiver until center diamond (1) appears.
Note: Tilt of unit should be >22.5° and <60° (T) to display offset depth.
4. Read the estimated distance (2, X).

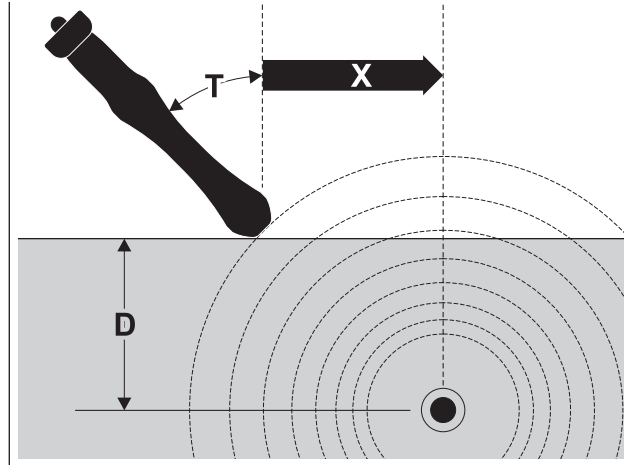

e18om027h.eps

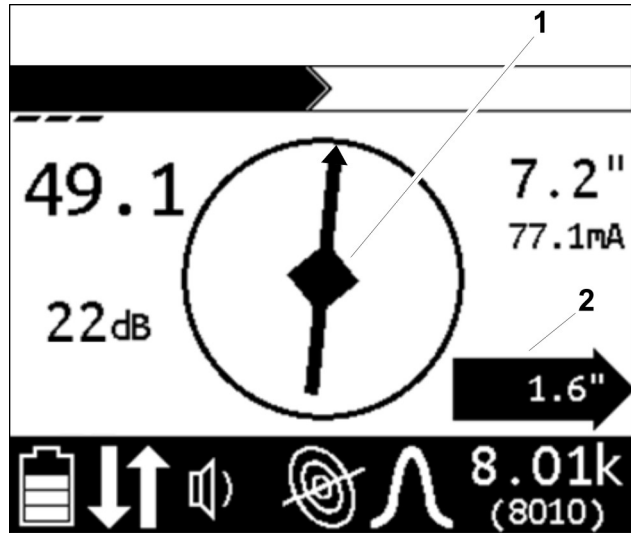

e18om038h.jpg

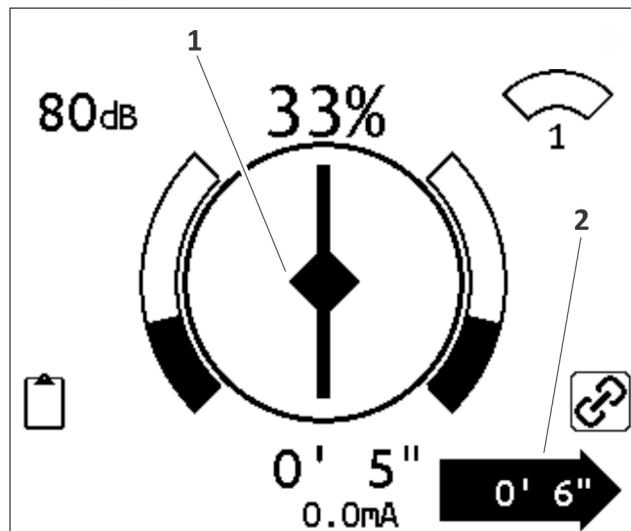

e24om005h19.png

High Power Output

IMPORTANT: When using high power output, either install a Lithium ion battery pack or connect the transmitter to an external power source.

High Power Output is a feature on UtiliGuard T12 and T12+ units. It allows the operator to transmit 12 watts on a line at frequencies less than 9kHz. Use this function on large diameter direct buried steel pipe and long distance locates.

To activate:

1. Navigate the transmitter menu to **Settings>Output>High Power**.
2. Select "Enable" or set timer as desired.

Mark the Cable

Sweep, focus, and trace all detected signals in the area. Mark cable paths with colored paint or flags. See the chart below for standard color markings for cable locations.

Utility	Color	Marking Symbol
electric	red	-E-
gas/oil	yellow	-G-
communications	orange	-TEL- or -TV-
water	blue	-W-
sewer	green	-S-



Special Situations

Situation	What to try
Signal is lost.	Walk in a circle to detect a tee or bend in the cable.
Signal varies from low to high and is unstable.	Mark as a hand-dig area.
You are near a power line and are receiving interference.	Sweep the area in 50 Hz or 60 Hz power mode. If receiver gives a strong signal response, a power line is interfering with transmitter signal.
Receiver does not function properly.	Receiver gain could be set too high or low. Lower or raise gain to locate the cable.
Target cable has connections to other cables.	Disconnect target cable from other cables or use direct connect or induction clamp to focus signal on target cable.
Signal is transferring to other cables.	<ul style="list-style-type: none"> • Lower the frequency. • Lower the power level. • Use direct connection, if possible, or use induction clamp. • Move the ground stake away from the target cable and away from other buried cables. • Apply signal at the point where the target cable is farthest from the other cables.

Locate Passive Signal

Setup

Follow setup procedures for the type of locating you will be doing. Always check receiver battery level at startup.

IMPORTANT: Cables with no A/C current flowing through them are hard to detect and may be hazardous because they may still have voltage potential. To locate, turn on an appliance to cause current to flow and use active search methods.

Technique

Survey the Site

Make a visual check of the site for signs of buried cables such as:

- recent trenching
- buried cable markers
- overhead lines that run down pole and underground
- gas meters
- valve sights
- drains or manhole covers

Sweep the Site

Search the site by walking a grid pattern while holding receiver close to the ground.

IMPORTANT: Keep receiver vertical.

Focus the Signal

Move receiver over detected signal to find best signal response. If using a peak antenna mode, rotate receiver until signal is best. Best signal indicates cable direction.

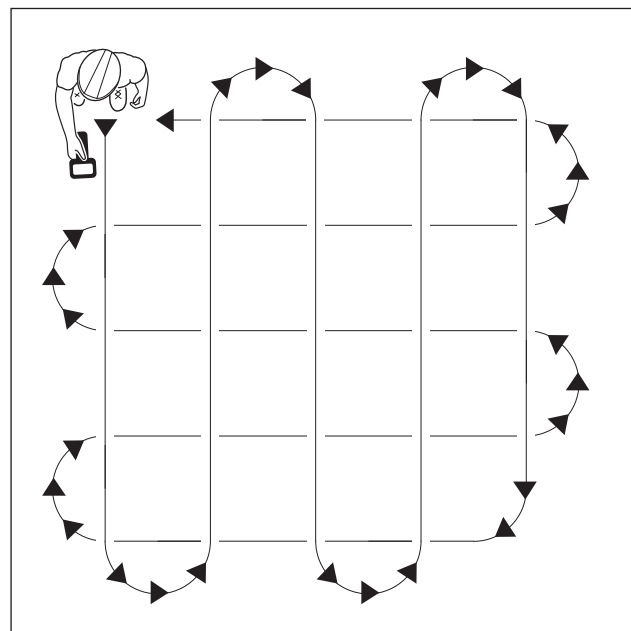

ss1076a-d.eps

Trace the Cable

Walk along the suspected path while moving the receiver from side to side across the area.

IMPORTANT: Keep receiver handle parallel to the suspected cable path.

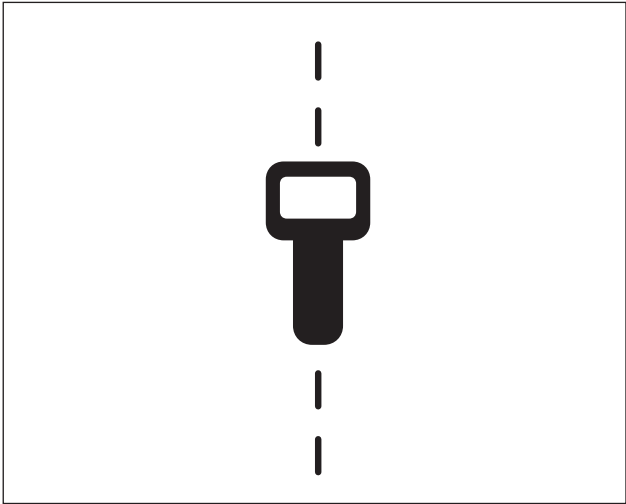

ss1080a-d.eps

Mark the Cable

Sweep, focus, and trace all detected signals in the area. Mark cable paths with colored paint or flags. See the chart below for standard color markings for cable locations.

Utility	Color	Marking Symbol
electric	red	-E-
communications	orange	-TEL- or -TV-

Special Situations

Situation	What to try
Signal is lost.	Walk in a circle to detect a tee or bend in the cable.
Signal varies from low to high and is unstable.	Mark as a hand-dig area.
Receiver does not function properly.	Receiver gain could be set too high or low. Lower or raise gain to locate the cable.

Locate Beacon Signal

Trace nonmetallic pipes or conduits by locating and following a beacon signal.

IMPORTANT: Large metal objects and other signals (such as railroad signals or overhead power lines) will distort signal.

Setup

1. Follow instructions for installing beacon battery.
2. Turn on receiver to ensure that beacon is functioning properly.
3. Attach beacon to plumber's snake or flex rod.

Technique

1. Turn on receiver.
2. Set operating mode to Beacon location.
3. Set antenna configuration to Total Field.
4. Place beacon into the pipe and move it down the pipe.
5. Locate beacon using peak or null methods. Peak location is the preferred method in most situations. Null point method is effective for locating deep beacons or for verifying the location of a beacon.

Null Point Method: Circle over approximate location. Follow directional arrows (2) to locate the null point (1). The beacon is correctly located at peak signal between null points.

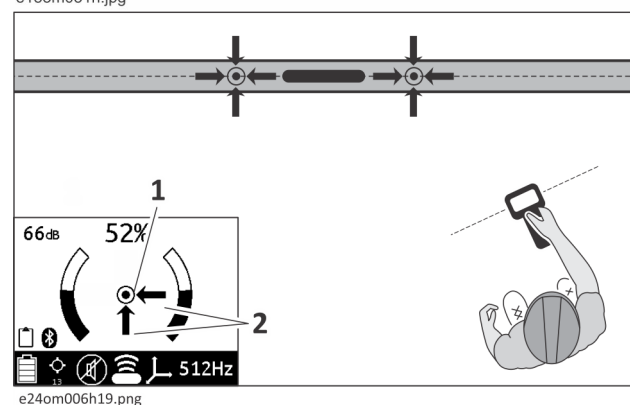
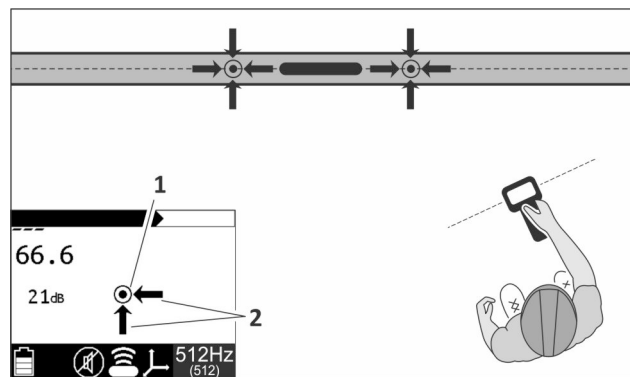

Peak Signal Method: When the peak signal is in range, rotation arrows will appear.

- Follow arrows (2) to rotate the receiver handle so that it is perpendicular to the beacon.
- Follow fore/aft arrow (1) to locate the approximate beacon position.

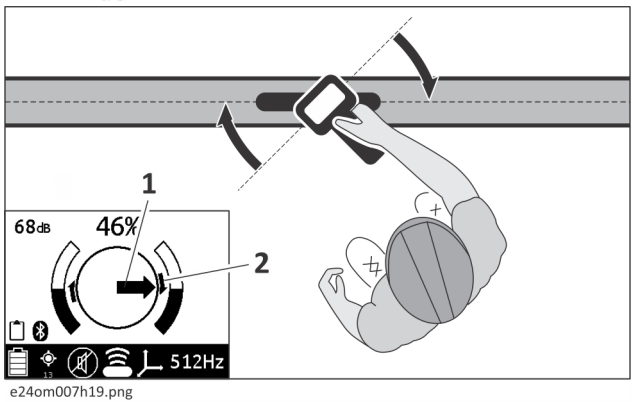
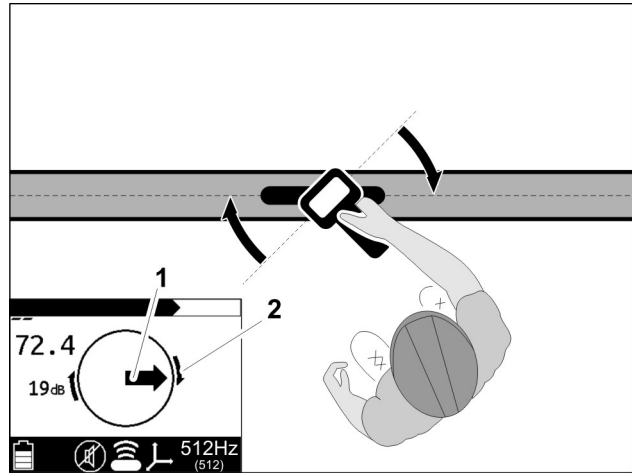

- Walk forward or backward to identify the location with the strongest signal response.

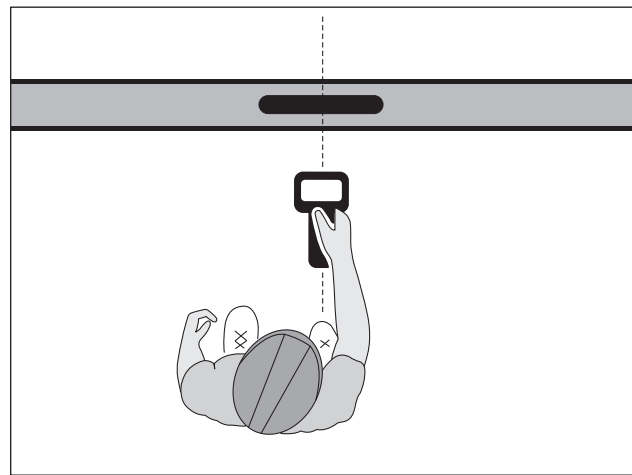

- When the beacon is correctly located, a diamond (1) will form in the center of the compass, the exterior arrows (2) will appear, and the signal (3) will be strongest. The depth reading will display.
- If operating in Manual depth, press the **Depth** key to estimate depth.

IMPORTANT: When estimating depth with a beacon in nonmetallic pipe, depth shown will be to the center of the beacon, not to the top of the pipe.

- Continue to track the beacon and observe depth readings. Mark pipe location with paint.

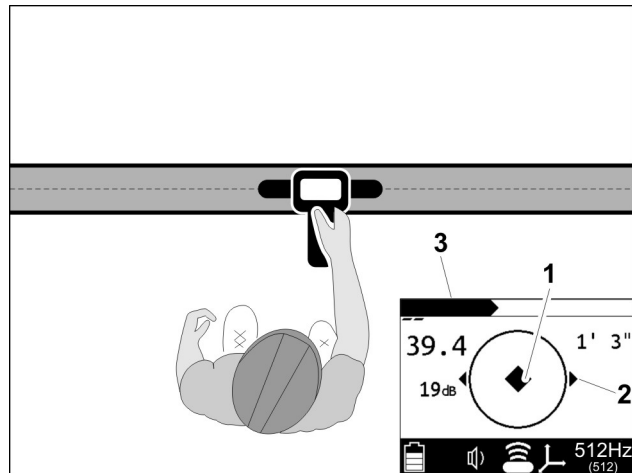

e18om033h.jpg

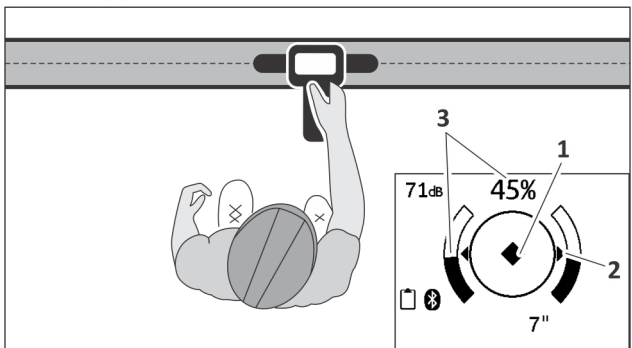

e24om008h19.png



Common Signal Problems

Distortions in the electromagnetic field around a cable can affect location accuracy. Tees, bends, parallel cables, crossing cables, or large metallic objects can distort signals. In areas where there is significant signal distortion or in places where the line being located is not straight, there may be places where the center diamond and the maximum twin signal do not occur in the same place. The left/right arrows and the center diamond are derived from the null antenna signal which is more susceptible to distortion than the peak antennas used for the twin signal. In locations where these signals do not agree, the twin signal is usually more accurate. Use caution when the center diamond and twin signal do not agree.

IMPORTANT: If target depth and location are critical, confirm by hand-digging or vacuum excavation.

Learn to recognize the following kinds of distortion:

Shadows

Shadows, also called blind spots, often happen when a metallic object partially obstructs the signal, or a signal from a parallel cable interferes with target signal.

Secondary (Ghost) Signals

A typical beacon signal pattern shows a main signal and two weaker secondary signals. Identify beacon location at the main signal. Familiarity with beacon signal patterns will lessen the effect of ghost signals. Using the Total Field antenna mode will eliminate ghost signals. See "Select Antenna Configuration" on page 46.

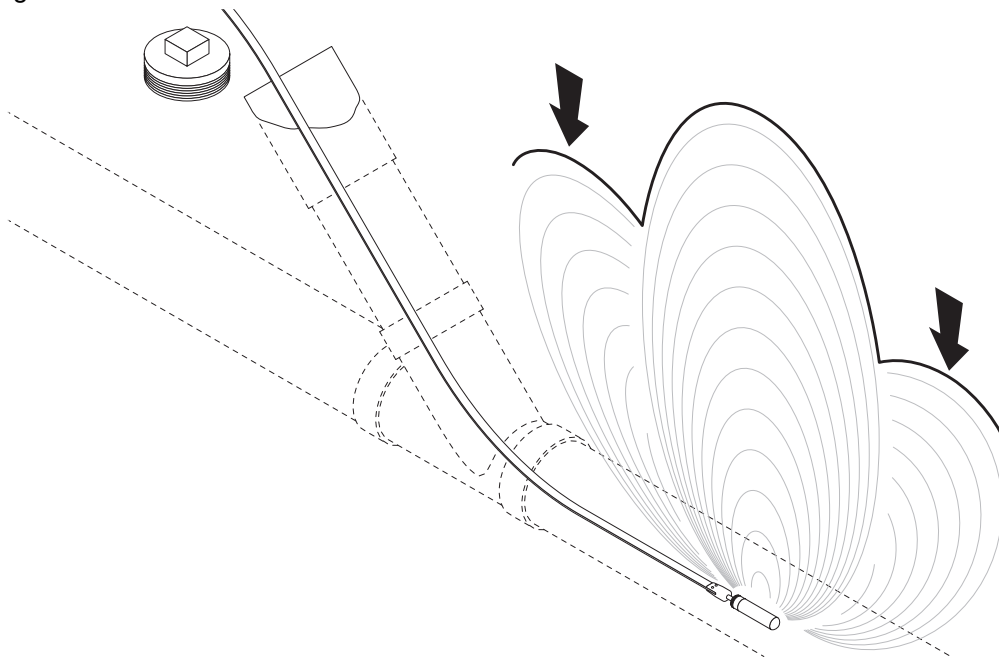

e180m039h.eps

Locate Faults

Background

How Earth Return Faults Are Created

When a direct-buried cable's insulation is damaged, the conductor is exposed to contact with the earth which creates a fault. If large enough, the fault can degrade the service provided by the cable. This type of fault is called an earth return fault. These damaged areas interact with the earth which causes corrosion that can further degrade the service.

Faults can be caused by a number of actions.

- Splicing: Corroded or damaged splices may fault to ground.
- Excavation: Cables can be nicked or broken by excavation equipment such as shovel, backhoe, trencher, drill head, auger, fence post, etc. These nicked areas can fault to ground and provide a place for corrosion to start.
- Abrasion: Rocks and other abrasive elements can damage cable when the earth shifts due to soil conditions, climate and above-ground traffic.



IMPORTANT: Although there are other types of faults, only earth return faults can be detected with this type of equipment.

Finding General Location of a Faulted Cable

Some things to look for when searching for the general location of a faulted cable are:

- recently disturbed soil
- past splices
- "buried utility" notices
- utility facilities without overhead lines
- junction boxes
- drop boxes
- light poles
- sunken ground

Fault Locating Concepts

Isolating the cable on both ends and then energizing it with a special signal generated by a transmitter creates an electrical circuit where current flows down the cable and seeks a path back to the transmitter. The path back to the transmitter is along the path of the fault to ground. Current will not flow without a path to ground.

Use a fault probe to probe the earth and measure the signal along the path of the cable. Signal will be highest at the point of the fault where the current enters the ground and at the transmitter ground stake. The arrows on the receiver point toward the direction of the fault.

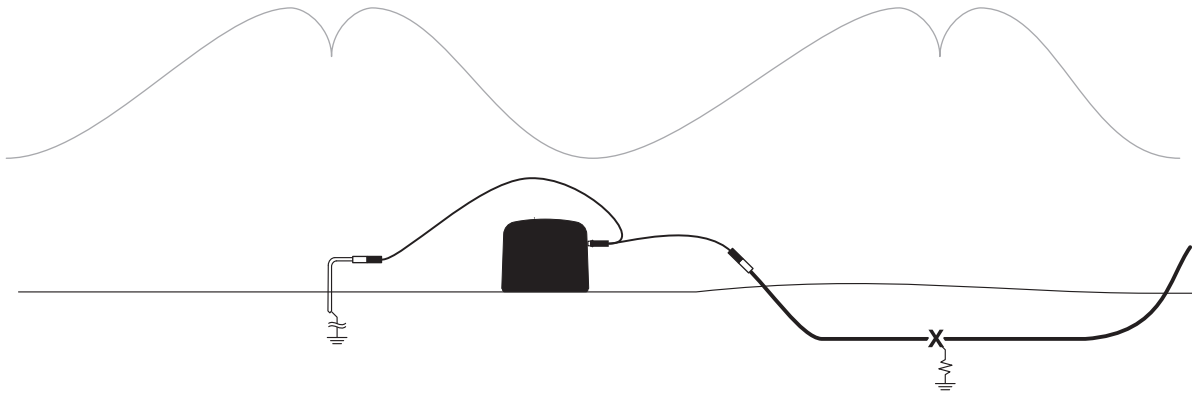

e18om019h.eps

As you move away from the transmitter, detector may stop indicating transmitter pulses. As you near the fault, detector will resume indicating transmitter pulses. This is normal. Transmitter pulses are strongest near the point of the fault (X) and at the transmitter ground. When probes straddle the fault or transmitter ground, signal will drop.

Setup

Transmitter

IMPORTANT:

- Fault Mode is not available on UtiliGuard T5B transmitters.
- Transmitter must be running Firmware Version 2 or greater.

1. De-energize and disconnect the cable at both ends. Turning off a breaker is usually not enough to isolate the cable for fault finding.
2. Plug direct connect lead into transmitter.
3. Connect black lead of the transmitter to the ground stake and connect the red lead to one end of the faulted cable.
4. Press the On/Off key to turn on fault transmitter.
5. Press and hold the Power Level key to enter menu.
6. Navigate down to Options Menu and press Power Level key to select.
7. Navigate down to Fault Mode and press Power Level key to select.

IMPORTANT: If direct connect leads are not plugged in, Fault Mode will not appear in menu.

8. Select "Enabled" by pressing Power Level key.
9. Transmitter will return to main screen and be in fault mode.

After the transmitter is connected to the cable, the impedance reading will help verify that a fault exists on the cable. While transmitter is in Fault Mode, the screen will show current, impedance and voltage. It will also be in power level 1. If current is below 5mA, increase power level until it shows 5mA or transmitter is at highest power level.

- Readings > 100k indicate no significant fault exists in the cable.
- Readings < 50k indicate a fault is likely.
- Higher transmitter power levels give better readings. Try a higher power level to ensure the cable is faulted.

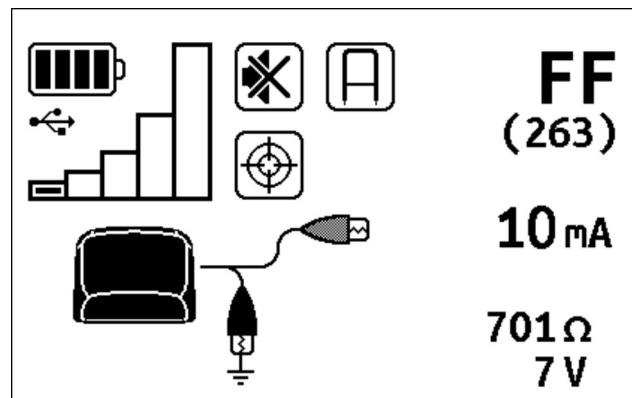

Receiver and Fault Probe

IMPORTANT:

- Fault Mode is not available on basic receivers.
- If receiver does not have 263Hz installed, fault finding will not work.
- Receiver must be running Firmware Version 6 or higher.
- The receiver can also locate cables while in Fault Mode but performance will vary based on the amount of current on the cable.

1. Press On/Off key to turn on receiver.
2. Plug fault probe into accessory port.
3. When fault probe is plugged into receiver, receiver will enter Fault Mode (probe icon will show) and flash a home symbol in the bottom right corner of the locate screen, as shown.
4. Connect transmitter to faulted cable following transmitter setup instructions. Select power level 1 or 2 on transmitter and observe adequate current on the cable (ideally at least 10mA).
5. With back toward transmitter, move down faulted cable a few feet (meters) from transmitter.

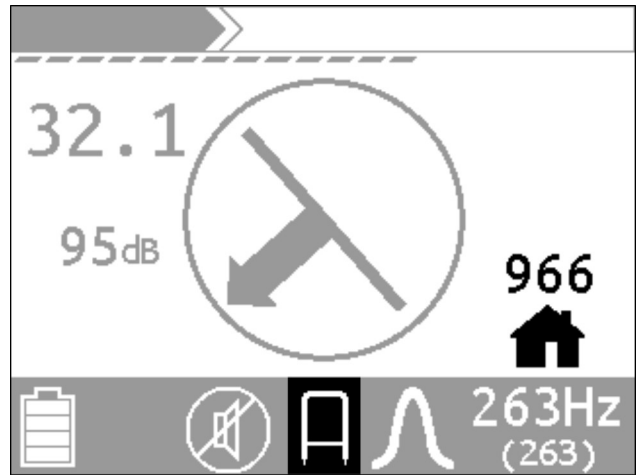

e18om064h.jpg

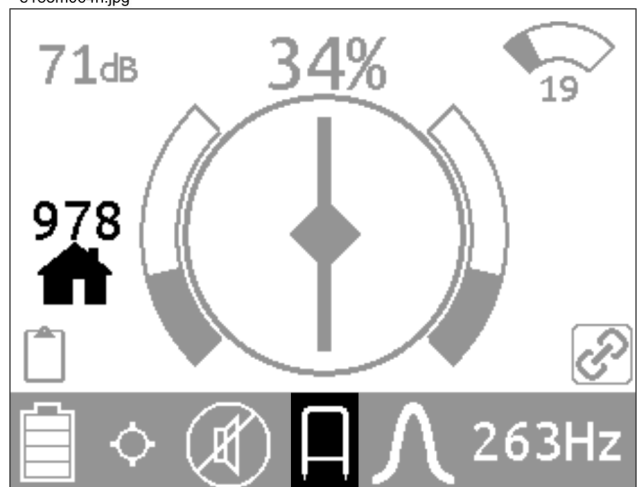

e24om015h19.png

6. Center fault probe over the cable and push it into the soil.
7. Numbers will appear above the flashing home icon. Once they do, press and hold Frequency key to home the fault system.
8. After system is successfully homed, a chime will sound and an arrow will appear, as shown. This indicates the fault is located toward the top of the screen.

IMPORTANT: Keep fault probe and receiver oriented the same while fault finding.

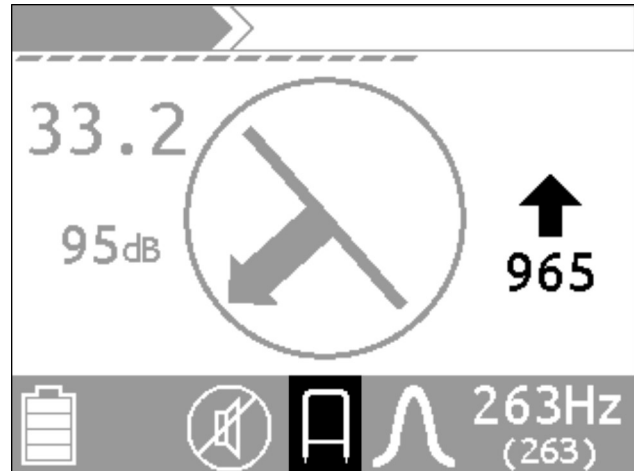

e18om065h.jpg

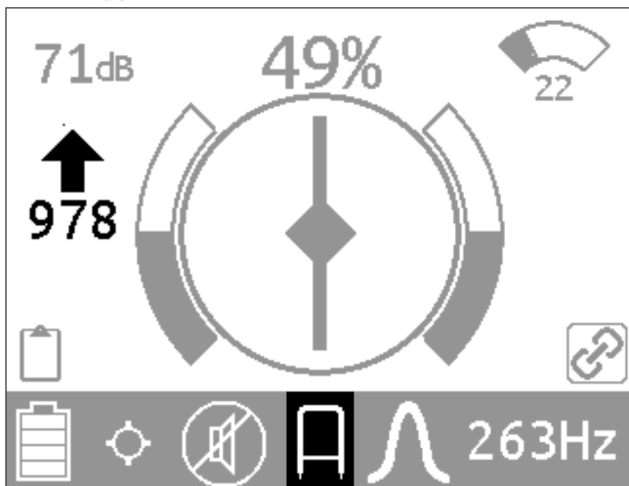

e24om016h19.png



Known Cable Route

After the receiver is homed, the receiver will display signal strength and direction if sufficient signal is present. If no signal is detected, detector will display "----" in center of screen. page 67

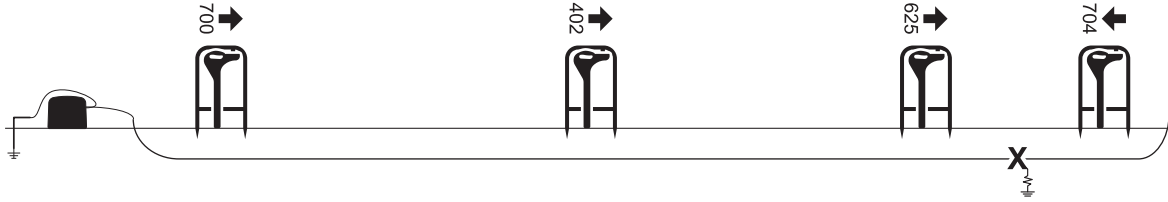

e13om062h.eps

1. Move 10' (3 m) down the cable route and insert fault probe again.
2. After arrows point in the opposite direction, insert detector a few feet (meters) back down the cable.
3. Repeat step 2 moving smaller distances until arrow changes direction after only a few inches (millimeters) of movement.
4. Rotate fault probe 90° and repeat location process until arrow switches direction after a small movement. Fault is directly between probes.

Unknown Cable Route

IMPORTANT: If possible, locate the cable with a receiver and mark the location. Then follow the instructions in "Known Cable Route" on page 70.

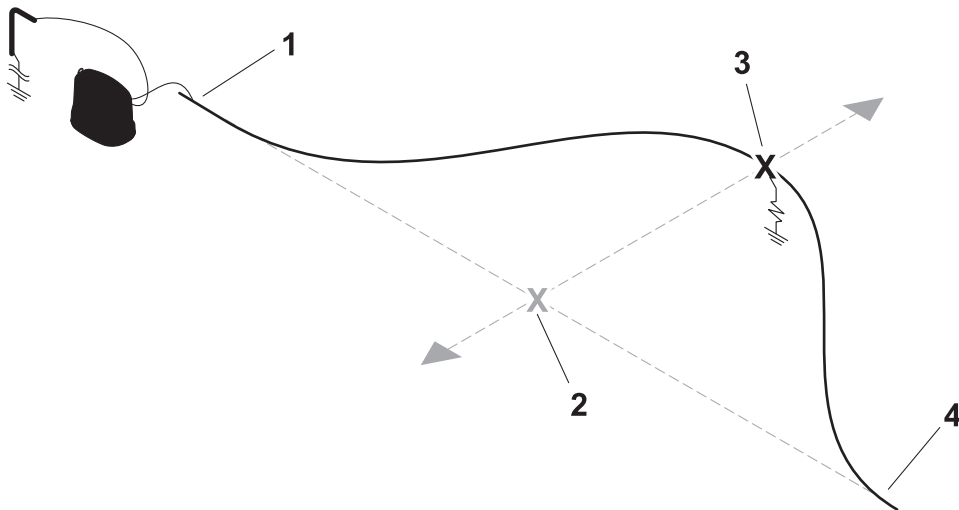

e18om018h.eps

1. Draw a straight line between the two disconnected ends (1, 4) of the isolated cable.
2. Follow the instructions in "Known Cable Route" on page 70.
3. Once fault is found (2) on straight line, turn fault probe 90° and find true location of fault (3).

Multiple Faults

After a fault is located and fixed, check the rest of the cable for other faults using the same process.

Locate Markers

Setup

1. Place receiver wand into recess of the EML accessory.
2. Insert strap (1) through buckle (2).
3. Tighten strap using buckle ratchet (3).

IMPORTANT: Do not over-tighten.

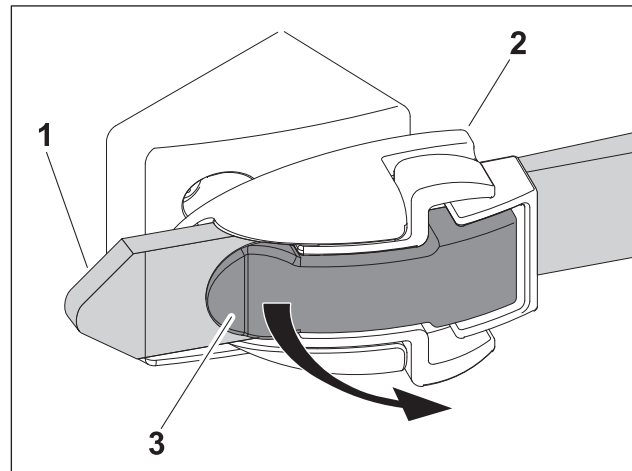

e18om073h.eps

4. Plug cable into receiver accessory connector (shown) behind spring-loaded door.
5. Turn receiver on. The receiver will enter EML Mode automatically and remain in EML Mode as long as EML accessory is plugged in and has sufficient battery power.

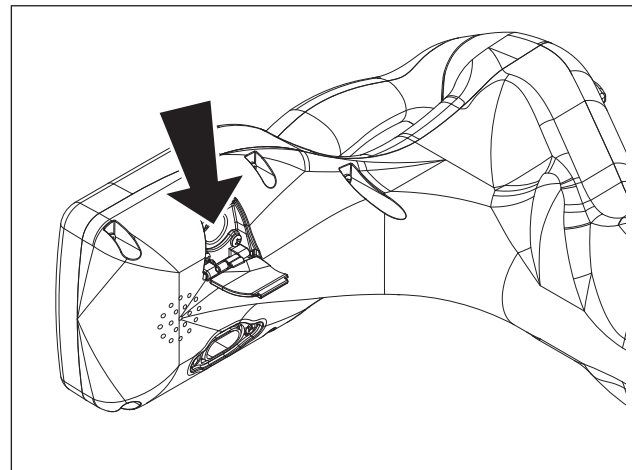

e18om076h.eps

To release:

1. Disconnect the EML cable from the receiver.
2. Place EML accessory on solid surface (ground, tailgate, etc.) and hold receiver wand (2) with left hand while pushing both levers (1) toward EML accessory with the right hand.
3. When buckle clicks, continue pressing levers and twist receiver to loosen strap enough to remove wand.

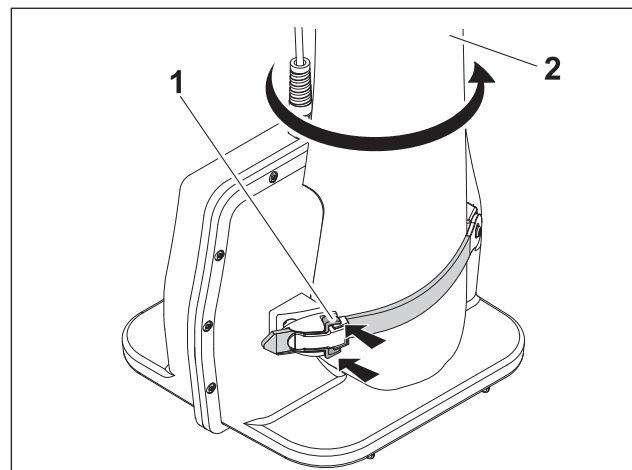

e18om072h.eps



Technique

Normal Marker Locating Mode

1. Attach EML accessory to the receiver.
2. Plug the EML cable into the receiver accessory connector.
3. Select marker type using the Frequency key.

IMPORTANT: Test unit for proper operation by passing the wand 3' (1 m) over a marker. Signal strength should increase and the bar graph should close.

4. Walk over area where you suspect a marker has been buried. Hold EML accessory close to the ground and move it from side to side. Move in the direction of increasing signal strength. Adjust gain as needed. Marker is located where receiver indicates maximum signal.
5. To locate next marker, adjust gain to 30 dB and repeat process.

Search Mode

If unsure about what markers are in the area, use Search Mode to locate all frequencies. After scanning for each frequency separately, the receiver displays the location information for the marker with the highest signal. Up and Down keys will adjust gain in this mode.

Locate with Receiver Clamp

1. Plug the receiver clamp cable into the accessory connector on the receiver.
2. Turn on the receiver. When clamp is plugged into receiver, receiver will enter clamp mode (clamp icon will show).
3. Use receiver frequency key to select desired frequency. Use mode key to toggle between active and passive power frequencies.
4. Compress the clamp handles together to open the clamp.
5. Place the clamp around the target line and release handles to close clamp.
6. Adjust the receiver gain using the up and down arrow keys to bring the received signal strength into range.

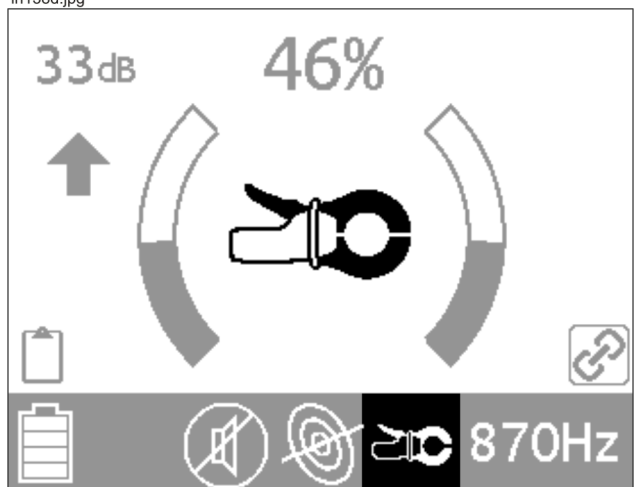
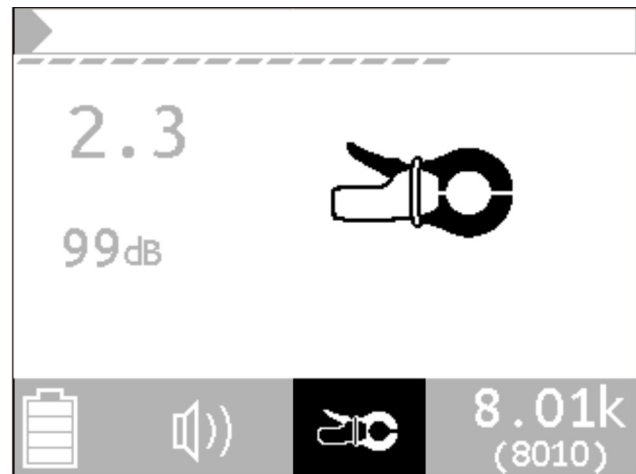

Locate with Stethoscope

1. Plug the stethoscope cable into the accessory connector on the receiver.
2. Turn on the receiver. When stethoscope is plugged into receiver, receiver will enter stethoscope mode (stethoscope icon will show).
3. Use receiver frequency key to select desired frequency. Use mode key to toggle between active and passive power frequencies.

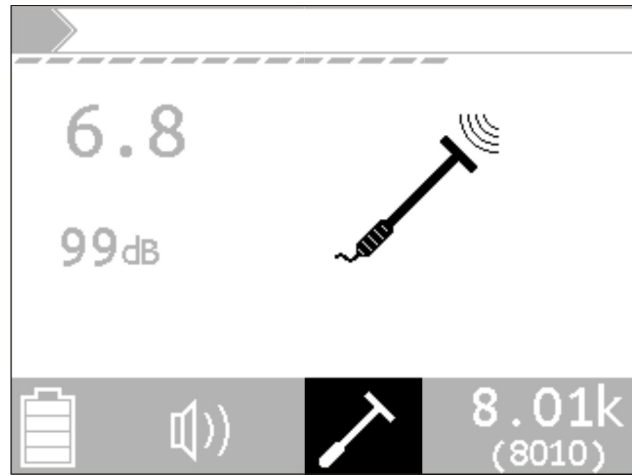

in137d.jpg

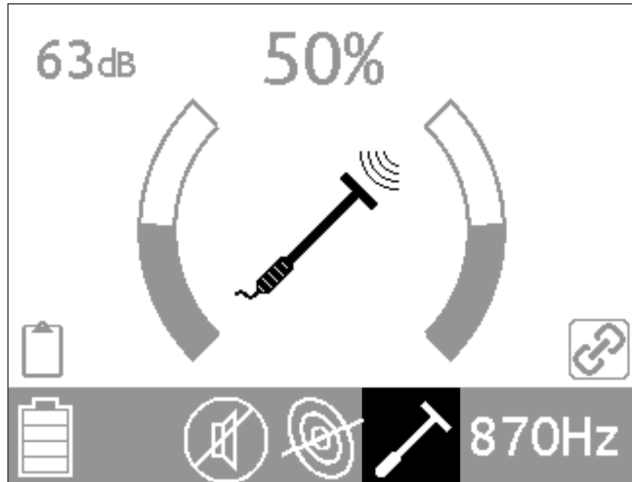

e24om018h19.png

4. Grip stethoscope by the handle and place the head (2) as close to the target line (1) as possible. Position the target line in the concave portion of the head as shown.

IMPORTANT: Adjust flexible neck as needed to improve positioning.

5. Adjust the receiver gain using the up and down arrow keys to bring the received signal strength into range.

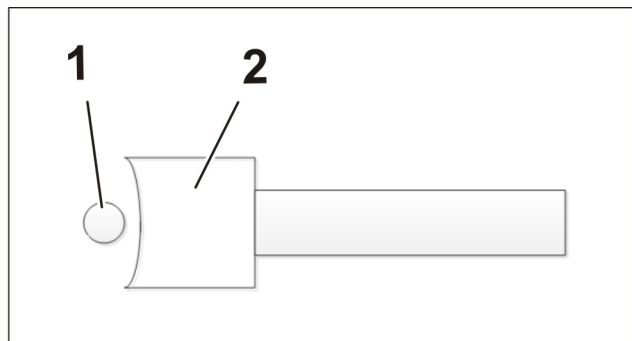

in136d.jpg

Locate Using GPS

Connect

Mapping Grade GPS

This method of logging location data is available on UtiliGuard+, UtiliGuard w/ Bluetooth®, UtiliGuard 2, and UtiliGuard 2+ receivers.

Prerequisites

- The GPS unit must have software that will recognize the data that is sent by the receiver.
- The GPS unit must support Bluetooth SPP connections.



Initial Pairing

This is required the first time a GPS device is connected to the receiver. To use a different GPS device, repeat this procedure.

1. Power on the GPS device and ensure its Bluetooth radio is active and discoverable. Refer to the GPS device manual for details.
2. Power on the receiver and go to the **Settings>Communications>Radio On/Off** menu and ensure the radio is “on”.
3. Initiate pairing from the GPS device. Refer to the GPS device manual for details.
 - The receiver will be named “MFLRX_xxxxxxx” where xxxxxxx is the serial number of the receiver.
 - If prompted for a passcode, it is “0000” (four zeros).
4. If applicable to the selected GPS device, choose “Serial Port” as the service type.

Connect to the GPS device

1. Launch the application software on the GPS device.
2. Connect to the receiver in the GPS application software.
 - For applications that connect to a COM port, ensure it is the **incoming** COM port.
3. On the UtiliGuard receiver, begin scanning for Bluetooth devices.:

UtiliGuard 1: Navigate to **Settings>Communications>Bluetooth>Connect**.

UtiliGuard 2: Navigate to **Configuration>Settings>Communications>Bluetooth>Connect**.

IMPORTANT: Ensure the GPS device is still discoverable.

4. Select the GPS device from the list. The receiver will begin the connection process..
5. On the main locate screen, the Bluetooth® icon should be on.

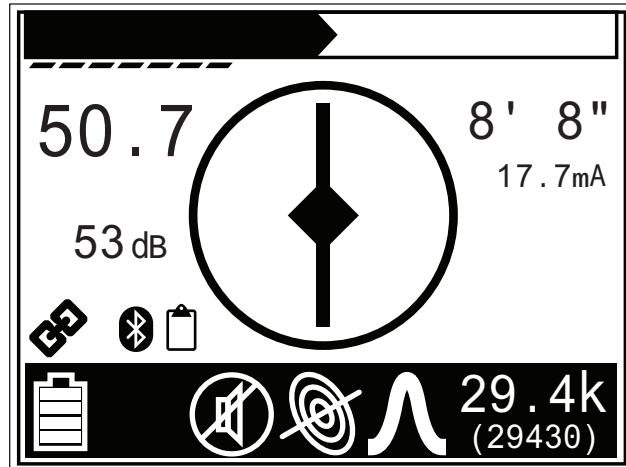

e18om001w.eps

Document Grade GPS

This method of logging location data is available on UtiliGuard+, UtiliGuard w/ Bluetooth, UtiliGuard 2, and UtiliGuard 2+ receivers.

1. Ensure you are in a location that the GPS can see satellites.
2. Turn on the GPS and ensure it is discoverable.
3. Turn on the receiver.

UtiliGuard:
Settings>Communications>Bluetooth>Connect menu.

UtiliGuard 2:
Configuration>Settings>Communications>Bluetooth>Connect.

4. Once the GPS is discovered, select it from the list.
5. On the main locate screen, the Bluetooth icon should be on and the GPS receive icon should appear.

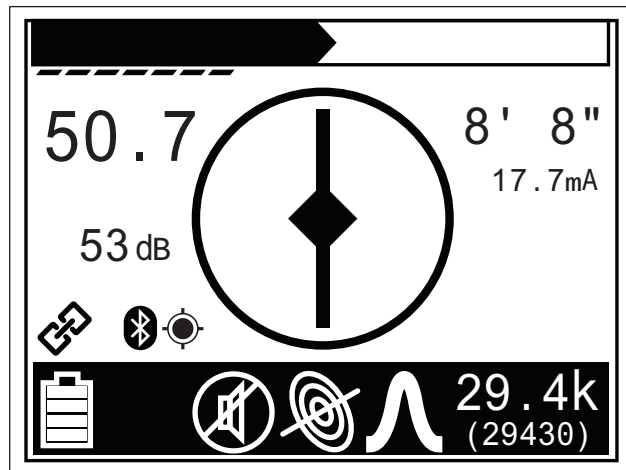

e18om002w.eps

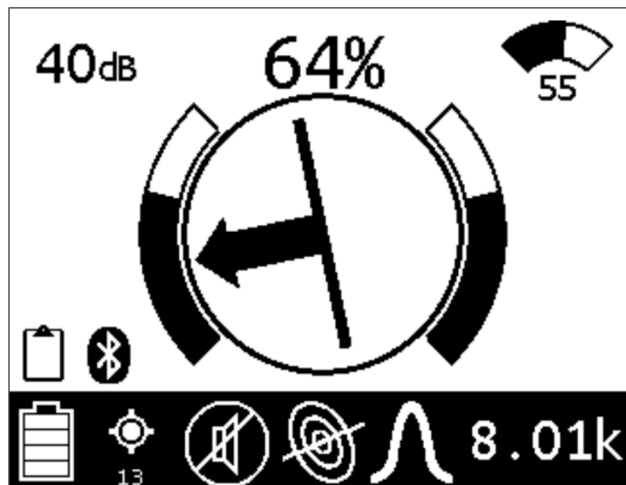

e24om020h19.png

Bluetooth® Accessory

This method of logging location data is available on UtiliGuard®+ and UtiliGuard w/ Bluetooth® receivers.

External Logging

This method of logging location data sends data from the UtiliGuard receiver to the GPS unit. This feature is only available on UtiliGuard+ and UtiliGuard w/ Bluetooth® receivers.

Prerequisites

- The GPS unit must have software that will recognize the data that is sent by the receiver.
- The GPS unit must support Bluetooth SPP connections.

Receiver to Device Connection

Initiate connection each time receiver is power-cycled and data logging is desired.

1. Turn on GPS device and ensure its Bluetooth® radio is active and discoverable. See GPS device manual for details.
2. Launch application software on the GPS device, if applicable.
3. Turn on the receiver and connect the Bluetooth accessory. The Bluetooth accessory icon will appear in the lower left corner of the receiver screen.
4. Go to the menu and select **Settings>Communications>Bluetooth>Connect GPS**.
5. Once the device is discovered and displayed on the receiver screen, select it from the list.
6. Receiver will display main locate screen. Bluetooth accessory icon will flash while making connection.
7. Receiver will connect and the logging device icon will appear.

The receiver will save the last device successfully connected with an OUTGOING connection and attempt to reconnect to that device on power up. The saved connection can be removed by selecting **Settings>Communications>Bluetooth>Unpair**.

If the saved connection is broken, the receiver will attempt to reconnect to the device for 60 seconds.

Device to Receiver Connection

1. Turn on the receiver and connect the Bluetooth accessory. The Bluetooth accessory icon will appear in the lower left corner of the receiver screen.
2. Scan for receiver using the GPS device. The Bluetooth accessory will be named "MFLBTD_xxxxxxx" where xxxxxx represents the serial number of the receiver.
3. Select the Bluetooth accessory and initiate the connection.
 - If prompted for a passcode, it is "0000" (four zeros).
 - If applicable to the selected GPS device, choose "Serial Port" as the service type.
4. Receiver will display main locate screen. Bluetooth accessory icon will flash while making connection.
5. After connection, the logging device icon will appear.



Internal Logging

This application stores data in the UtiliGuard[®] receiver for downloading later using the locator downloader software. This feature is only available on UtiliGuard+ and UtiliGuard w/ Bluetooth[®] receivers.

Initiate connection each time receiver is power-cycled and data logging is desired.

Receiver to Device Connection

1. Turn on the GPS device and ensure its Bluetooth radio is active and discoverable. Refer to the GPS device manual for details.
2. Turn on the receiver and connect the Bluetooth accessory. The Bluetooth accessory icon will appear in the lower left corner of the receiver screen.
3. Go to the menu and select **Settings>Communications>Bluetooth>Connect GPS**.
4. Once the device is discovered and displayed on the receiver screen, select it from the list.
5. Receiver will display main locate screen. Bluetooth accessory icon will flash while connection is being made.
6. Once device connects and sends data to the receiver, the GPS icon will appear.

The receiver will save the last device successfully connected with an OUTGOING connection and attempt to reconnect to that device on power up. The saved connection can be removed by selecting **Settings>Communications>Bluetooth>Unpair**.

If the saved connection is broken, the receiver will attempt to reconnect to the device for 60 seconds.

Device to Receiver Connection

1. Turn on the receiver and connect the Bluetooth accessory. The Bluetooth accessory icon will appear in the lower left corner of the receiver screen.
2. Scan for receiver using the GPS device. The Bluetooth accessory will be named "MFLBTD_XXXXXX" where XXXXXX represents the serial number of the receiver.
3. Select the Bluetooth accessory and initiate the connection.
 - If prompted for a passcode, it is "0000" (four zeros).
 - If applicable to the selected GPS device, choose "Serial Port" as the service type.
4. Receiver will display main locate screen. Bluetooth accessory icon will flash while connection is being made.
5. Once device connects and sends data to the receiver, the GPS icon will appear.

MyUtiliGuard[®] App

This method of logging location data is available on UtiliGuard 2, and UtiliGuard 2+ receivers.

Prerequisites

- iOS 9.3 or greater
- Android 5.0 or greater

Initial Pairing

1. Ensure Bluetooth[®] radio is active and discoverable. See mobile device manual for details.
2. To connect receiver, see MyUtiliGuard operator's manual. The receiver will be named "MFLRX_xxxxxx" where xxxxxx represents the serial number of the receiver.
3. Confirm Bluetooth code on mobile device and receiver.



Prepare to Locate

1. Initialize logging on mobile device. For advanced logging options, see MyUtiliGuard operator's manual.
2. Stow mobile device.

Log Point

To store a point, force a depth from the main locate screen push and hold the bottom left button on the keypad (shown). The user should hear a low tone if data is stored instead of a high tone.

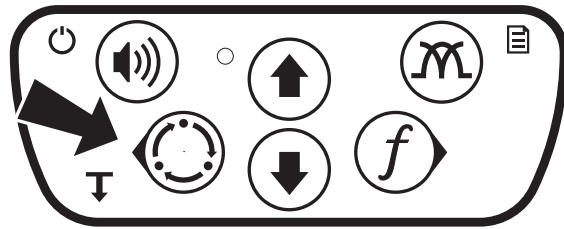

If a high tone sounds when forcing the depth button the receiver is not storing data. Reconnect to the GPS.

Troubleshooting	
Either the GPS device or receiver is "unpaired"	Un-pair or remove the other device from both devices and repeat the "Initial Pairing" procedure.
Pairing fails	If the GPS device does not support Secure Simple Pairing, the passcode consisting of four zeros (0000) must be entered to complete pairing.
The connection fails from the "Connect GPS" menu	Repeat the connection attempt by selecting the GPS device again.
GPS device does not show up in the "Connect GPS" menu.	Ensure the GPS device's Bluetooth® radio is active and it is discoverable. Some devices only remain discoverable for a few minutes. Check the device's Bluetooth settings.
The receiver is not found by the GPS device during pairing.	Ensure the receiver is "On" in the Settings>Communications>Radio On/Off menu. The receiver will revert to "Off" after power-cycling if no devices are paired.
Continued failed or lost connections	Hardware on certain GPS devices may not be compatible with the receiver's Bluetooth. Contact Subsite Product Support. Using the Bluetooth Accessory may be required.

Download

Document Grade GPS

Go to <http://updates.subsite.com/locators/LogDownloader/setup.exe> and download the Locator Log Downloader file. Once the software is downloaded the GPS data stored in the receiver can be retrieved.

1. Connect the USB cable from the PC to the UtiliGuard Standard BT or the UtiliGuard+ (Advanced) receiver.
2. Double click on the locator log downloader icon. The software will automatically connect to the receiver and begin downloading stored information.
3. Once the software has downloaded the GPS information, it will give you an option to save the Log.
4. Click on the save log button. This will pull up a box allowing changing the file name and changing the file type to either a .KML file or a .CSV file.
5. Once finished saving, the log downloader will give you an option to clear the receiver log data or close the utility.



IMPORTANT: It is recommended to clear the data off of the receiver after every download.

Bluetooth® Accessory

Internal Logging

Go to <http://updates.subsite.com/locators/LogDownloader/setup.exe> and download the Locator Log Downloader file. Once the software is downloaded, the GPS data stored in the receiver can be retrieved.

1. Connect the USB cable from the PC to the UtiliGuard®+ (Advanced) or UtiliGuard w/ Bluetooth receiver.
2. Double click on the locator log downloader icon. The software will automatically connect to the receiver and begin downloading stored information.
3. Once the software has downloaded the GPS information, it will give you an option to save the Log.
4. Click on the save log button. If desired, change the file name and change the file type to either a .KML file or a .CSV file.
5. Once finished saving, the log downloader will give you an option to clear the receiver log data (recommended) or close the utility.

MyUtiliGuard® App



See MyUtiliGuard operator's manual for download instructions.

Use Configuration Management System

Certain UtiliGuard receivers (Advanced, Standard, Standard with Bluetooth®, UtiliGuard 2, and UtiliGuard 2+ models) allow configuration of the available receiver frequencies, modes, and antenna functions to customize or simplify the operation of compatible UtiliGuard receivers.

Additionally, operations supervisors can lock access to the configuration menu to use the receivers as part of their operator training and competency skills assessment program. Later, they can reconfigure to add in advanced product features for more-skilled users.

Configure Frequencies, Modes and Functions

- To enter Configuration Management System, press antenna configuration key  until function is enabled. Then press and release the frequency key .
- From configuration menu, use up and down arrow keys to select frequencies, modes or antennas to configure.
- Press frequency key to change settings for selected function.
- Press up and down arrow keys to select items within the selected function.
- Press frequency key to enable (check) or disable selected feature.
- Press location mode key  to exit the configuration sub menu.
- Repeat steps for other features until all configuration is finished and press the location mode key to exit the configuration sub menu.
- Press location mode key again to exit Configuration Management System.

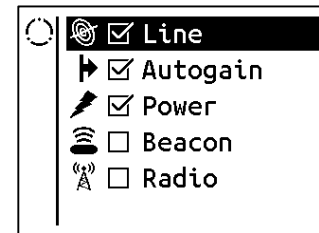
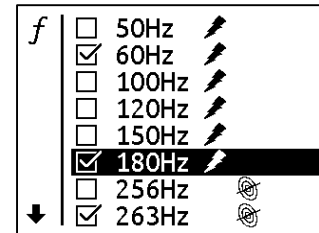
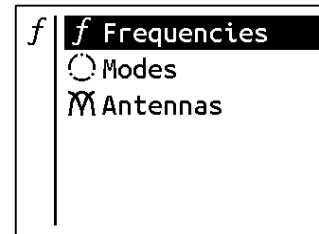
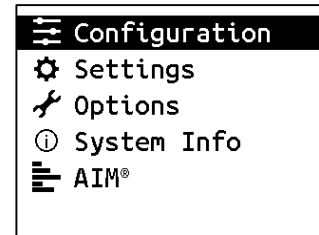

IMPORTANT: If a padlock icon is displayed at the top left corner of the display, the settings cannot be altered until configuration is unlocked.

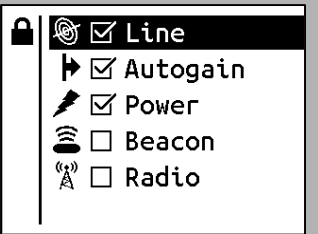

The screenshot shows the "Line" menu with a padlock icon in the top left corner, indicating that the settings are locked.

Lock/Unlock Configurations

Lock

1. To lock configuration settings, download the Locator Configurator Utility from Subsite® Electronics at <https://subsite.com/support/software-updates>.



UTILIGUARD®

INSTALL USB DRIVERS ►

INSTALL CONFIG UTILITY ►

How to Install Software:

Click each install button above to download and install 1) USB drivers, then 2) the configuration utility.

- Internet Explorer Users: Select 'Run' once the file is downloaded.
- Other browsers: Open your browser downloads folder and click on the setup.exe file.

Requires Windows Vista SP2 or newer.

LOG DOWNLOADER ►



2. Follow instructions on download page to install the configuration utility.
3. Remove receiver USB connection cover and connect supplied USB cable from PC to the UtiliGuard receiver. The receiver will come on and display the USB icon in upper left corner.

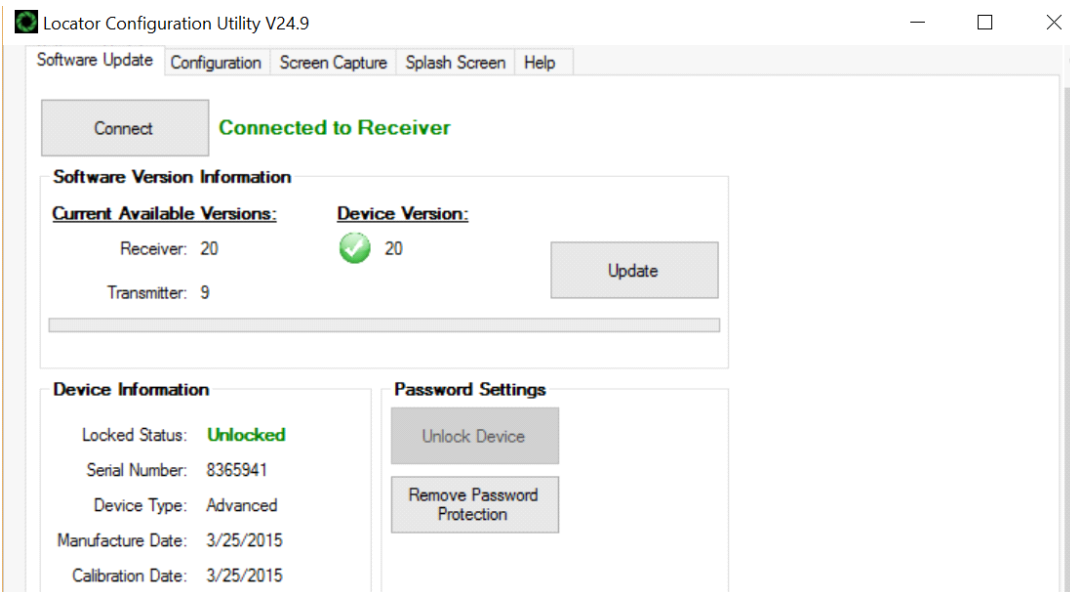

4. Press Connect.
5. Press Password Protect Device.
6. Enter a password of any length.
7. Confirm password. Once password is accepted, a message will pop up.
8. Confirm on the software update tab that the configuration menu has been locked.
9. Exit the configuration utility, disconnect USB cord from receiver and computer and turn off receiver.
10. Turn on receiver and verify settings are locked.

Unlock

To unlock configuration settings, launch the configurator utility, follow steps 3 and 4 above and press Unlock Device. Enter password.

IMPORTANT: Receiver must be unlocked by Subsite[®] Product Support if password is forgotten.

To remove password protection from the receiver, select Remove Password Protection.

Service

Chapter Contents

General Care	86
As Needed	86

General Care

Under normal operating conditions, receiver, transmitter, fault probe, Live Power Adapter, receiver clamp, and stethoscope need only minor maintenance. Following these care instructions can ensure longer equipment life:

- Do not drop the equipment.
- Do not expose the equipment to high heat (such as in the rear window of a vehicle).
- Clean equipment with a damp cloth and mild soap. Never use scouring powder.
- Do not immerse in any liquid.
- Inspect housing daily for cracks or other damage. If housing is damaged, contact your equipment dealer for replacement.
- Do not mix new and used batteries.

As Needed

Location	Task	Notes
Receiver Unit	Change batteries	2 "D" alkaline
Transmitter Unit	Change batteries	10 "D" alkaline or Li-ion
EML Accessory	Change batteries	10 "AA" alkaline

Receiver Unit

Change Batteries

Use 2 D-cell alkaline batteries in receiver.

1. Remove battery cover.
2. Insert batteries as shown.
3. Install and tighten battery cover.
4. Check operation.

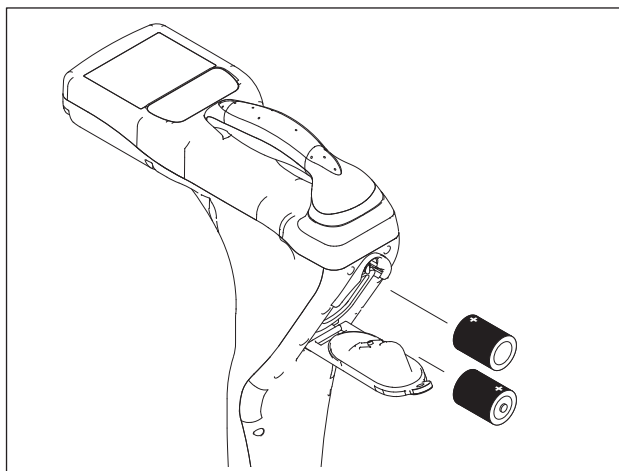

e18om003h.eps

Transmitter Unit

Change Batteries

Use ten D-cell alkaline batteries or a Lithium-ion battery pack in transmitter.



WARNING Battery cells inside may vent or rupture. Do not crush, do not heat or incinerate, do not short circuit, do not dismantle, do not immerse in any liquid. Observe charging instructions.

To help avoid injury, see battery manufacturer's safety instructions.

1. Open battery cover.
2. Insert batteries as shown.

IMPORTANT:

- Installing batteries backwards will cause damage to batteries and unit.
- Ensure that door is closed tightly.
- Do not mix new and used batteries.

3. Close and tighten battery cover.
4. Check operation. If battery light is flashing when unit is turned on, then one battery is incorrectly installed or batteries are weak.

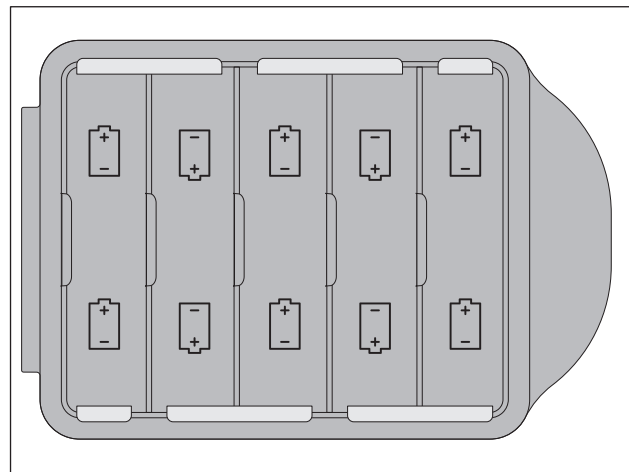

e18om008h.eps

Li-ion Battery Pack

Handling

- Avoid shorting the battery.
- Do not immerse in water.
- Do not disassemble or deform the battery. Never use a battery that appears to have suffered abuse.
- Do not expose battery to fire. Do not dispose of the battery in fire.
- Avoid excessive physical shock or vibration.

Charging

- Battery must be charged in an appropriate charger only. Never use a modified or damaged charger.
- Charge at 32°F to 113°F (0°C to 45°C) in less than 80% relative humidity.

Storage and Disposal

- Dispose of in accordance with local regulations.
- Store in a cool, dry, and well-ventilated area. Storage limits: -4°F to 140°F (-20°C to 60°C), <80% relative humidity.
- For best results, store battery pack in an environment free from corrosive gas at a temperature less than 70°F (21°C). Extended exposure to temperatures above 113°F (45°C) could degrade battery performance and life.
- If storing battery pack for an extended period, charge or discharge to pack to 30-50% remaining capacity. This will give at least 6 months of shelf life at room temperature before electronics go into shutdown mode. Charge the battery every 6 months if longer storage is required.
- After the battery has self-discharged for an extended time, the electronics will disconnect from the internal cells. The battery will exist in this storage state for approximately one year at room temperature before the cells discharge to the point beyond which they should not be charged.

EML Accessory

Change Batteries

Use ten AA-cell alkaline batteries in transmitter.



WARNING Battery cells inside may vent or rupture. Do not crush, do not heat or incinerate, do not short circuit, do not dismantle, do not immerse in any liquid. Observe charging instructions.

To help avoid injury, see battery manufacturer's safety instructions.

1. Open battery cover.
2. Remove battery holder.
3. Insert batteries in holder as shown.

IMPORTANT:

- Installing batteries backwards will cause damage to batteries and unit.
- Do not mix new and used batteries.

4. Place battery holder in battery compartment.
5. Close and tighten battery cover.

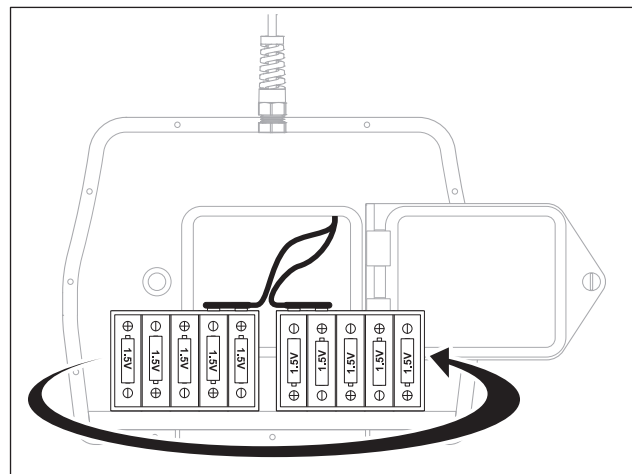

e18om069h.eps

Live Power Adapter Accessory

Replace Fuse

Disconnect the live power adapter from the transmitter and the target line before replacing the fuse. With a flat blade screwdriver, turn fuse cap counterclockwise. Remove cap and remove fuse. Place the new FF2.5A 500V fuse in the cap. Replace cap and attach by turning cap clockwise.

Specifications

Receivers

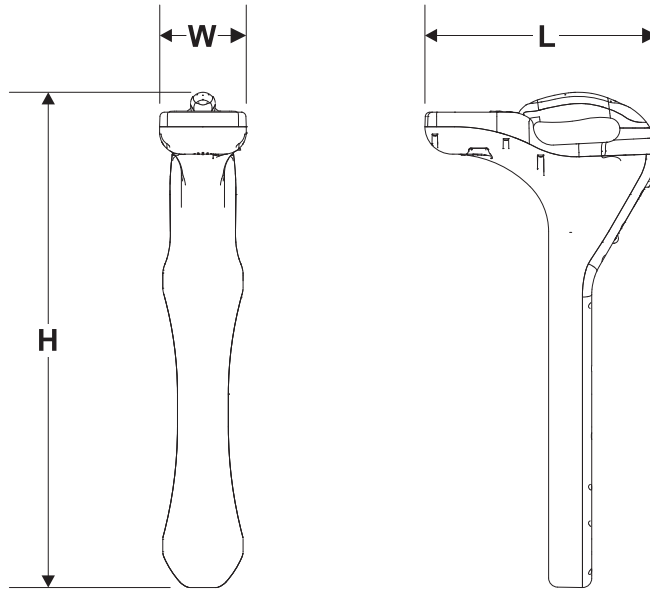

e18om001h.eps

Dimensions		U.S.	Metric
H	Height	27.2"	69.09 cm
L	Length	12.8"	32.50 cm
W	Width	4.8"	12.19 cm
	Weight	4.8 lb	2.18 kg

Operation		U.S.	Metric
Operating temperature range		-4°F to 122°F	-20°C to 50°C
Storage temperature range		-25°F to 158°F	-32°C to 70°C
Depth, max autodepth		20'	6 m
Depth, max forced		40'	12 m

IP rating: IP65

Antenna configurations: single peak, twin peak, null, left/right (cable only)

Audio output: speaker

LCD backlight: LED

External ports: Mini USB

Operation	U.S.	Metric
-----------	------	--------

Maximum power output: 12 watts*

*Only available in Direct Connect mode, below 9kHz.

Batteries	U.S.	Metric
-----------	------	--------

Type: 2 D-cell alkaline

Life:	UtiliGuard: continuous use at 70°F/21°C, approximately 30 hours; intermittent use, approximately 60 hours
	UtiliGuard 2: continuous use at 70°F/21°C, approximately 20 hours; intermittent use, approximately 50 hours

Battery saver: unit shuts off after 5, 10, 20, or 30 minutes inactivity according to user setting, if selected

Transmitters

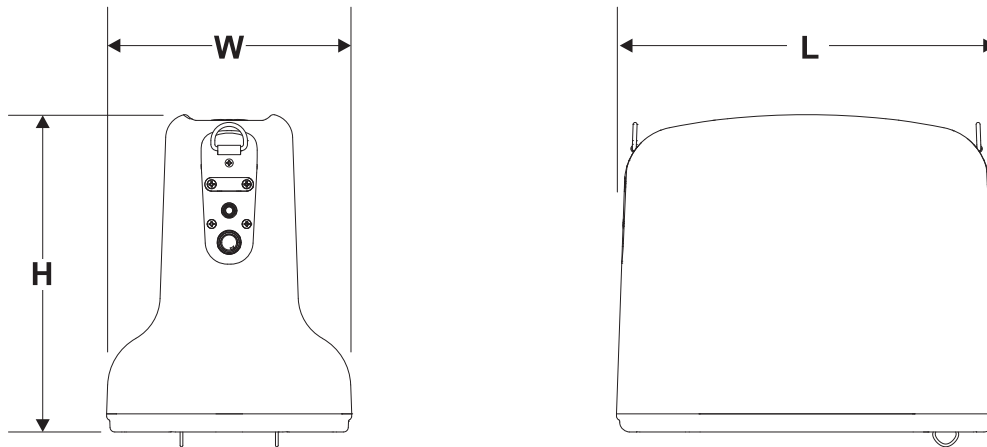

e18om002h.eps

Dimensions		U.S.	Metric
H	Height	10"	25.40 cm
L	Length	12"	30.48 cm
W	Width	7.8"	19.1 cm
	Weight	7.8 lb	3.54 kg
Operation		U.S.	Metric
Operating temperature range		-4°F to 122°F	-20°C to 50°C

IP rating: IP65

Maximum power output: 12 watts

Timer: unit runs continuously or shuts off after 2, 4 or 8 hours of inactivity, according to user settings.

Batteries

Type: 10 D-cell alkaline or 1 lithium ion battery pack (p/n 220-2221)

Life: continuous use at power level 2): Alkaline - approximately 100 hours; Lithium ion approximately 80 hours.

Performance	U.S.	Metric
Bluetooth® standard	Bluetooth v2.1 Class 1	
Operating frequency	2.402-2.480 MHz	
Operating range	2132.5 ft	650m
Transmit power	17dBm	

System Operation

Operating Modes and Frequencies

Active cable, standard: Up to 100 frequencies

Passive cable, standard: 60 Hz, 120 Hz, 180 Hz, 50 Hz, 100 Hz, 150 Hz

Beacon, optional (locate/depth only): any frequency.

Radio, optional (locate only)

Locating Ranges	U.S.	Metric
Cables	15'	4.6 m
Beacons	10'	3 m
Depth Estimate Tolerances*	U.S.	Metric
Passive cable ±10%	0.5-10'	0.15-3 m
Active cable ±5%	0.2-10'	0.2-3 m
Beacon ±5%	0.5-10'	0.15-3 m

* Locators are calibrated at factory frequencies to these tolerances under ideal test conditions. Actual operating conditions may have signal distortions or noise sources which result in depth estimate errors. Above tolerances do not apply to offset depth estimates.

Fault Finder

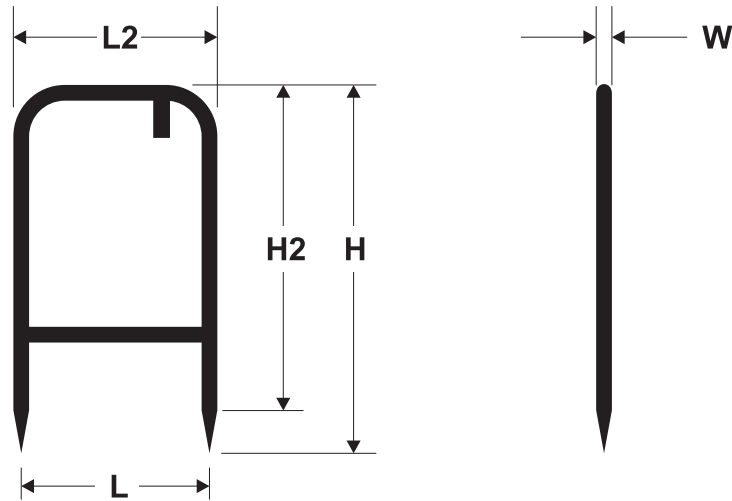

e18om068h.eps

Dimensions	U.S.	Metric
L, length between probes	12 in	305 mm
L2, handle length	13 in	330 mm
H, height from probe tip to carrying handle	29.2 in	742 mm
H2, height from probe base to carrying handle	24.3 in	617 mm
W, width	1.0 in	25 mm
Weight	4.8 lb	2.2 kg

Compatibility

Transmitter must be running Firmware Version 2.0 or higher.
 Receiver must be running Firmware Version 6.0 or higher.

EML Accessory

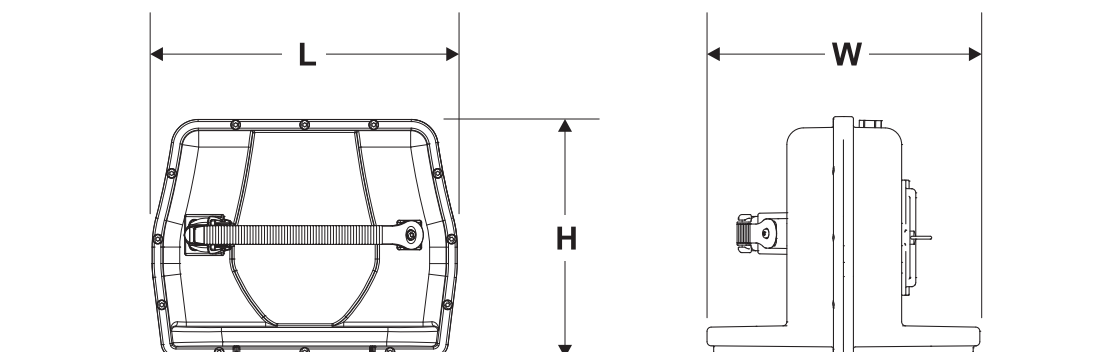

e13om067h.eps

Dimensions	U.S.	Metric
L, length	9.3 in	236 mm
H, height	7.3 in	185 mm
W, width	8.2 in	208 mm
Weight, without batteries	2.5 lb	1.2 kg
Weight, with batteries	3.0 lb	1.4 kg
Operational		
Marker frequencies: 66.35 kHz (non-potable water), 77.0 kHz (cable television), 83.0 kHz (gas), 101.4 kHz (telephone), 121.6 kHz (sewer); 134.0 kHz (electric power - EU countries); 145.7 kHz (water); 169.8 kHz (electric power - non-EU countries)		
IP rating: IP65		
Operating temperature range: -4°F (-20°C) to 122°F (50°C)		
Battery		
Type: 10 AA-cell alkaline. Life: 20 hours at low power		
Compatibility		
Receiver must be running software version 7.0 or higher.		

Live Power Adapter Accessory

Dimensions	U.S.	Metric
L, length	4.9 in'	124 mm
H, height	1.9 in	48 mm
W, width	3.2 in	81 mm
Weight	2.0 lb	0.9 kg
Cable length, transmitter side	10 in	254 mm
Cable length, utility side (retracted coils)	25 in	635 mm
Operational		
Operating temperature range: -4F (-20C) to 122F (50C)		
Input: 480V 50/60 Hz		
Output: 10VAC 50/60 Hz		
Fuse: F2.5A 500V		

Bluetooth® Accessory

Dimensions	U.S.	Metric
L, length	0.8 in	20.3 mm
H, height	3.45 in	87.6 mm
W, width	1.0 in	25.4 mm
Weight	0.05 lb	0.023 kg
Operational		
Operating temperature range: -4F (-20C) to 122F (50C)		
Voltage and current: 3.1 V DC nominal/45 mA maximum		
Contains FCC ID: T7VEBMU and IC: 216QEBMU		

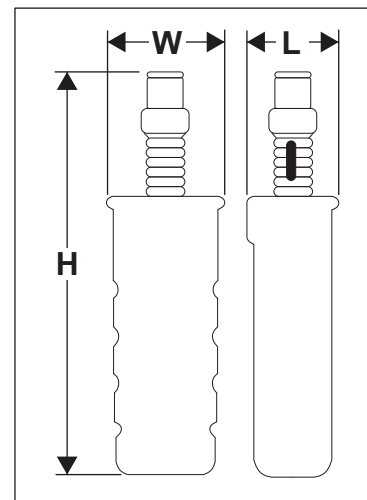

e18om004w.eps

Support



Procedure

Notify your dealer immediately of any malfunction or failure of Subsite[®] Electronics equipment.

Always give model, serial number, and approximate date of your equipment purchase. This information should be recorded and placed on file by the owner at the time of purchase.

Return damaged unit to dealer for inspection and warranty consideration if in warranty time frame.

All repairs must be done by an authorized Subsite Electronics repair facility. Repairs done elsewhere will void warranty.

Resources

Publications

Contact your Ditch Witch[®] dealer for publications and videos covering safety, operation, service, and repair of your equipment.

Training

For information about on-site, individualized training, contact your Ditch Witch dealer.

Warranty

Electronics Limited Warranty Policy

Subject to the limitation and exclusions herein, free replacement parts and labor will be provided when a unit fails due to a defect in material or workmanship within one (1) year of first commercial use (See Exceptions below for specific products). Defects shall be determined through inspection by Manufacturer or authorized repair centers. An inspection must occur within thirty (30) days of the date of failure of the product or part by Manufacturer or its authorized repair facility. Manufacturer will provide the location of its inspection facilities or its nearest authorized dealer upon inquiry. Manufacturer reserves the right to supply remanufactured replacement parts under this warranty as it deems appropriate. Each warranty repair carries the remainder of the factory warranty or 90 days, whichever is longer, for all repaired components and labor.

Product Warranty Exceptions:

- HDD guidance beacons, Locate Beacons and Accessories carry a six (6) month warranty.
- HDD guidance beacons, T-Series, carry a three (3) year 750-hour warranty.
- All Used (Cosmetic) Electronics products sold from Manufacturer carry a six (6) month warranty from date of sale to dealer.

EXCLUSIONS FROM PRODUCT WARRANTY

- All defects or damages caused by misuse, abuse, improper installation, alteration, neglect, modification, lack of maintenance, or uses other than those for which products were intended.
- All defects, damages, or injuries caused by improper training, operation, or servicing of products in a manner inconsistent with manufacturer's recommendations.
- All batteries, which are considered consumable and therefore not covered under this warranty.
- All damaged plastics are considered to be the result of misuse or neglect unless Manufacturer has determined otherwise.
- All repairs or attempted repairs by non-certified repair facilities or personnel will void the warranty.
- All incoming duties and freight charges.

(Exclusions from Product Warranty, continued)



- Manufacturer reserves the right to make changes in design and/or improvements to products from time to time, and user understands that Manufacturer shall have no obligation to upgrade any previously manufactured product to include any such changes.
- In no event shall Manufacturer or its agents, assigns or parent company be liable for any indirect, special, incidental, or consequential damages or for any cover, loss of information, profit, revenue or use based upon any claim by user for breach of warranty, breach of contract, negligence, strict liability or any other legal theory. In no event shall Manufacturer liability exceed the amount user has paid for the Manufacturer product.
- Manufacturer will not be responsible for loss of accessories or loss or erasure of data storage media.
- Should it be determined that applicable law prohibits enforcement of any provision of this Warranty Policy, then to the extent it is necessary to comply with the applicable law, this Warranty Policy shall be deemed amended.
- This Warranty Policy shall be the entire agreement between Manufacturer and the Purchaser. Any statements that purport to be different than or modify or expand the terms set forth in this written policy are not effective for any purpose. ANY IMPLIED WARRANTIES, INCLUDING WARRANTIES OF MERCHANTABILITY AND FITNESS FOR A PARTICULAR USE ARE EXPRESSLY DISCLAIMED. IN NO EVENT SHALL SUBSITE® ELECTRONICS, THE CHARLES MACHINE WORKS, INC., OR ANY AUTHORIZED SERVICING AUTHORITY BE RESPONSIBLE FOR ANY LOSSES, INCLUDING CONSEQUENTIAL AND INCIDENTAL DAMAGES, EXCEPT AS EXPRESSLY PROVIDED HEREIN.

SERVICE AND REPAIR

- Units repaired at Manufacturer's location or an authorized service center will carry a 90-day warranty on all replaced components/parts and labor commencing on the date of repair.
- HDD guidance beacons, T-Series repairs: If a lower assembly is replaced on any T-Series beacons the 750-hour count will start over at zero (0) hours. The warranty years will continue from date of product registration.
- TX Series beacons that are updated to T-Series beacons will have a 90-day repair warranty.
- T-Series beacons that are past the three (3) year warranty will have a 90-day repair warranty.

EXTENDED WARRANTY

Consult your local Subsite dealer for extended warranty options.

WARRANTY DETAILS

For information regarding this warranty policy, contact Subsite Product Support Department at (800)846-2713 ext. 1; mail us at 1950 W. Fir, Perry, OK 73077; or your local dealer.

